

LOCH

**Diamant-Werkzeuge
für Verbundwerkstoffe**

*Diamond Tools
for Composite Materials*



JAKOB LACH GmbH & Co. KG
Donaustr. 17 · D-63452 Hanau
Telefon +49-61 81-103 0
Fax +49-61 81 - 103 860
www.lach-diamant.de
office@lach-diamant.de







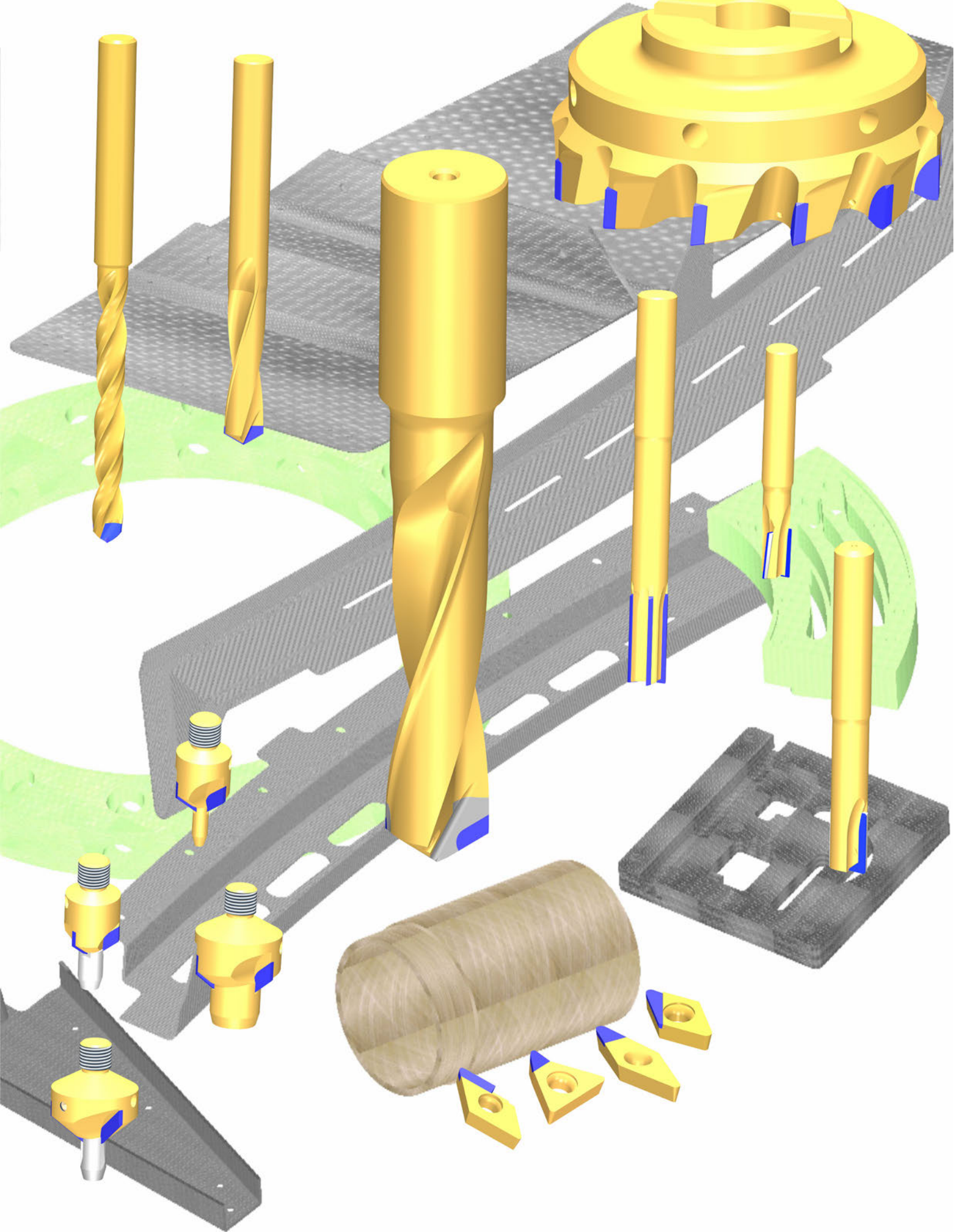

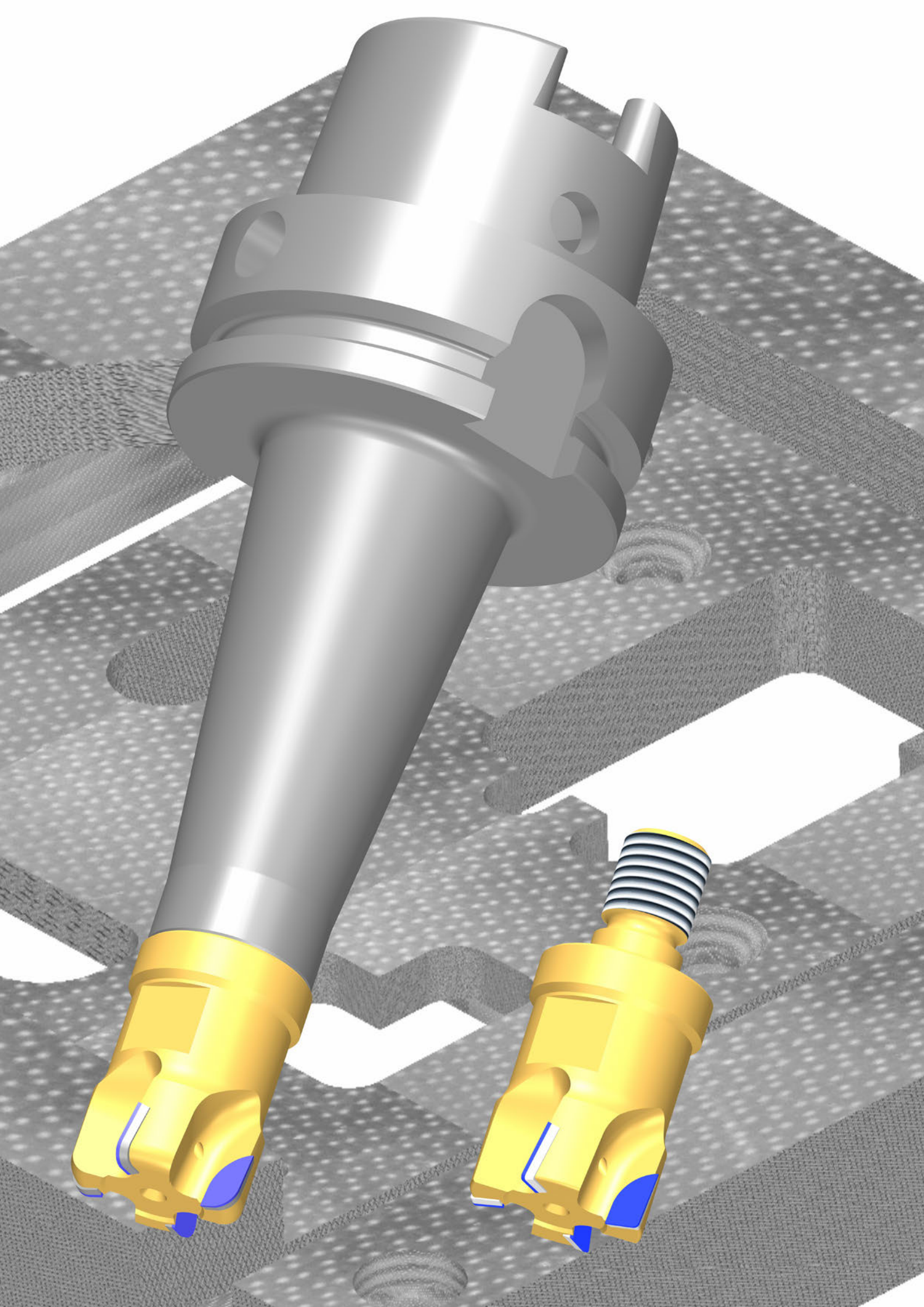











**LACH
Diamant**

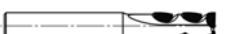







PKD-Zerspanungswerkzeuge PCD Cutting Tools

PKD-Spiralbohrer mit spiralisiertem PKD Type PS <i>PCD Twist drills with twisted PCD</i>		6
PKD-Spiralbohrer mit spiralisiertem PKD Type P <i>PCD Twist drills with twisted PCD</i>		7
PKD-Stufenbohrer mit spiralisiertem PKD Type P <i>PCD Step drills with twisted PCD</i>		8
PKD-Spiralbohrer mit spiralisiertem PKD Type S <i>PCD Twist drills with twisted PCD</i>		9
PKD-Spiralbohrer mit kombinierter PKD/HM-Schneide Type XP <i>PCD Twist drills with combined PCD/carbide cutting edge</i>		11
PKD-Spiralbohrer mit Dachformschneiden Type W <i>PCD Twist drills with solid self-centering cutting edges</i>		12
Hohlbohrer mit PKD-Wechsel-Schneidplatten Type WSH <i>Hollow drills with PCD indexable inserts</i>		13
PKD-Zapfensenker – ein- und zweiteilige Ausführung <i>PCD Countersinks – solid and two piece design</i>		14
PKD-Schaftfräser Type SMS <i>PCD End mills</i>		16
PKD-Schaftfräser mit positivem Spanwinkel Type SMP-C <i>PCD End mills with positive cutting angle</i>		18
PKD-Schaftfräser mit Wechsel-Achswinkel Type SMSWA <i>PCD End mills with shear cut application</i>		19
PKD-Schaftfräser mit großem Achswinkel Type SMSXX <i>PCD End mills with extreme shear cut</i>		20
PKD-Vielzahn-Schaftfräser Type SMM / SMV <i>PCD Multiple end mills</i>		21
PKD-Vielzahn-Schaftfräser Type SMZ <i>PCD Multiple end mills</i>		23
PKD-»dia-compact«-Monoblock-Einschraubfräser Type MBC-E <i>PCD »dia-compact« Monoblock milling cutters for adapting</i>		24
PKD-»dia-compact«-Monoblock-Plan-/Eckfräser Type MBC-H <i>PCD »dia-compact« Monoblock face and square shoulder milling cutters</i>		25
PKD-»dia-compact«-Monoblock-Plan-/Eckfräser Type MBC-X <i>PCD »dia-compact« Monoblock face and square shoulder milling cutters</i>		26
»dia-compact«-Plan-Eckfräser mit Kassetten <i>»dia-compact« face and square shoulder milling cutters with cartridges</i>		27
PKD-Kassetten für Plan-Eckfräser. <i>PCD Cartridges for face and square shoulder milling cutters</i>		28

Galvanische Diamant-Schleifwerkzeuge Electroplated Diamond Grinding Tools

Diamant-Trennscheiben G-SY <i>Diamond cutting discs G-SY</i>		30
Diamant-Entgrat- und Fräswerkzeuge G-SY <i>Diamond deburring and milling tools G-SY</i>		31
Diamant-Hohlbohrer G-SY <i>Diamond hollow drills G-SY</i>		32
Diamant-Schaftfräser G-SY <i>Diamond router bits G-SY</i>		33

dreborid®-D

PKD-Spiralbohrer - mit spiralisiertem PKD

PCD Twist Drill - with twisted PCD

Type PS

empfohlen für die Fertigbearbeitung von Composites, CFK, GFK, Aluminiumlegierungen über 11% SiC

recommended for finishing composites, CFRP, GRP, aluminium alloys above 11 % Sic

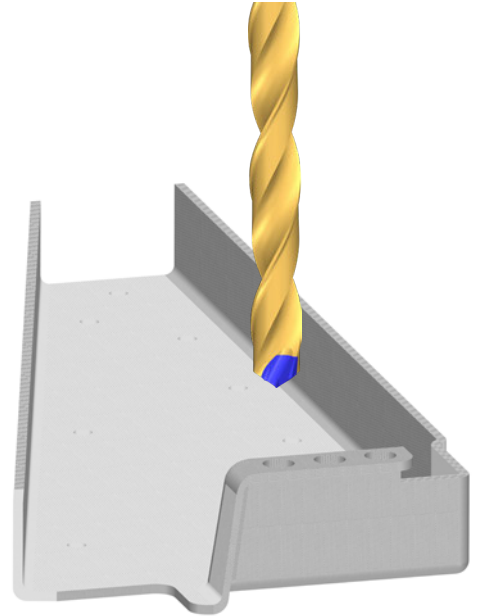

nach ISO 235
according to ISO 235

DIN 1897					DIN 338				
D1	D2	L2	L1	Art. No.	D1	D2	L2	L1	Art. No.
3	3	16	46	42401500	3	3	33	61	42401510
4	4	22	55	42401501	4	4	43	75	42401511
5	6	26	62	42401502	5	6	52	86	42401512
6	6	28	66	42401503	6	6	57	93	42401513
7	8	34	74	42401504	7	8	69	109	42401514
8	8	37	79	42401505	8	8	75	117	42401515
9	10	40	84	42401506	9	10	81	125	42401516
10	10	43	89	42401507	10	10	87	133	42401517
11	12	47	95	42401508	11	12	94	142	42401518
12	12	51	102	42401509	12	12	101	151	42401519

Bestellangaben: D-Spiralbohrer Typ PS D1 - L2 - L1 / Art. No.
Order Code: D-Twist Drill Type PS D1 - L2 - L1 / Art. No.

Bestellbeispiel: D-Spiralbohrer Typ PS Ø3,0 - 16 - 46 / 42401500
Order Example: D-Twist Drill Type PS Ø3,0 - 16 - 46 / 42401500

Andere Abmessungen und Ausführungen maßgeschneidert nach Ihrer Vorgabe
Custom-made dimensions according to your specifications

Nachschleifservice für alle PKD- und CBN-Werkzeuge

dreborid®-D PKD-Spiralbohrer mit spiralisiertem PKD PCD Twist Drill with twisted PCD

Type P

besonders empfohlen für die Bearbeitung von Grün-Keramik
und Grün-Hartmetall, Graphit, GFK
*especially recommended for drilling green ceramics
and green carbide, graphite, GRP*

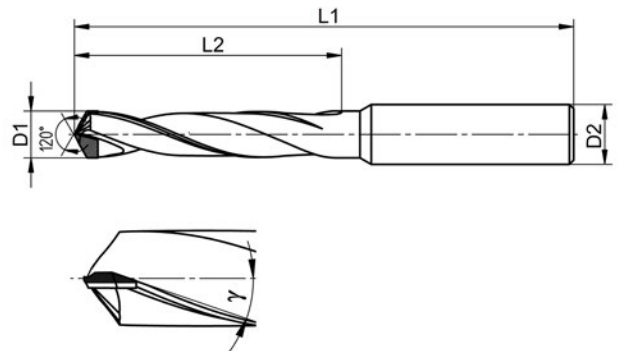
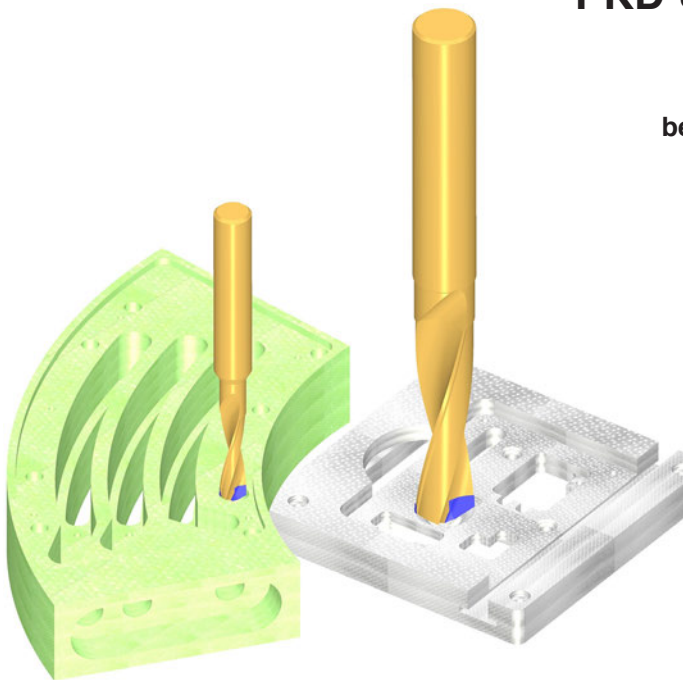

nach ISO 235
according to ISO 235

DIN 1897					DIN 338				
D1	D2	L2	L1	Art. No.	D1	D2	L2	L1	Art. No.
3	3	16	46	42401600	3	3	33	61	42401614
4	4	22	55	42401601	4	4	43	75	42401615
5	6	26	62	42401602	5	6	52	86	42401616
6	6	28	66	42401603	6	6	57	93	42401617
7	8	34	74	42401604	7	8	69	109	42401618
8	8	37	79	42401605	8	8	75	117	42401619
9	10	40	84	42401606	9	10	81	125	42401620
10	10	43	89	42401607	10	10	87	133	42401621
11	12	47	95	42401608	11	12	94	142	42401622
12	12	51	102	42401609	12	12	101	151	42401623
13	14	51	102	42401610	13	14	101	151	42401624
14	14	54	107	42401611	14	14	108	160	42401625
15	16	56	111	42401612	15	16	114	169	42401626
16	16	58	115	42401613	16	16	120	178	42401627

Bestellangaben: D-Spiralbohrer Typ P D1 - L2 - L1 / Art. No.
Order Code: D-Twist Drill Type P D1 - L2 - L1 / Art. No.

Bestellbeispiel: D-Spiralbohrer Typ P Ø3,0 - 16 - 46 / 42401600
Order Example: D-Twist Drill Type P Ø3,0 - 16 - 46 / 42401600

Andere Abmessungen und Ausführungen maßgeschneidert nach Ihrer Vorgabe
Custom-made dimensions according to your specifications

Resharpening Service for all PCD and CBN Cutting Tools

dreborid®-D

PKD-Stufenbohrer mit spiralisiertem PKD

PCD Step Drill with twisted PCD

Type P

empfohlen für die Fertigbearbeitung von hochwertigen Composite- und CFK-Bauteilen

recommended for finishing high-grade composite and CFRP components

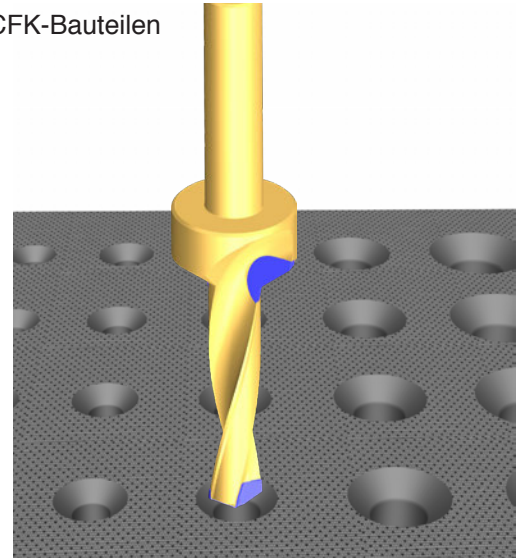
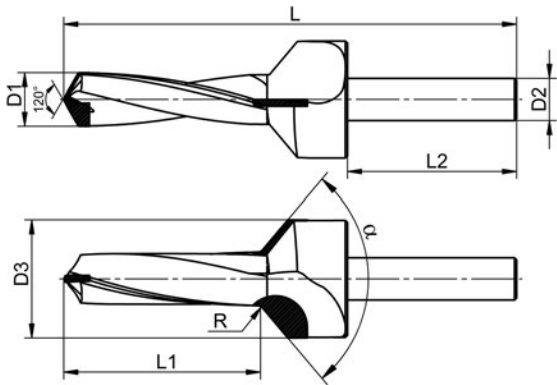

nach Werksnorm

according to factory standard

D1	D2	D3	L	L1	L2	α	R	Art. No.
4,76	10	12	90	30	40	100	0,5	42401950
5,56	10	14	90	30	40	100	0,5	42401951
6,35	10	16	90	30	40	100	0,5	42401952
7,94	10	18	90	30	40	100	0,8	42401953
9,53	10	20	90	30	40	100	0,8	42401954
11,12	10	22	90	30	40	100	1,0	42401955
12,70	10	24	90	30	40	100	1,0	42401956

Bestellangaben: D-Stufenbohrer Typ P D1 - L1 - α - R - D3 - L - D2 - L2 / Art. No.

Order Code: D-Step Drill Type P D1 - L1 - α - R - D3 - L - D2 - L2 / Art. No.

Bestellbeispiel: D-Stufenbohrer Typ P Ø4,76 - 30 - 100 - R0,5 - 12 - 90 - 10 - 40 / 42401950

Order Example: D-Step Drill Type P Ø4,76 - 30 - 100 - R0,5 - 12 - 90 - 10 - 40 / 42401950

Andere Abmessungen und Ausführungen maßgeschneidert nach Ihrer Vorgabe
Custom-made dimensions according to your specifications

Nachschleifservice für alle PKD- und CBN-Werkzeuge

dreborid®-D
PKD-Spiralbohrer mit spiralisiertem PKD
PCD Twist Drill with twisted PCD

Type S

empfohlen für die Fertigbearbeitung von CFK, Composites
recommended for finishing CFRP, composites

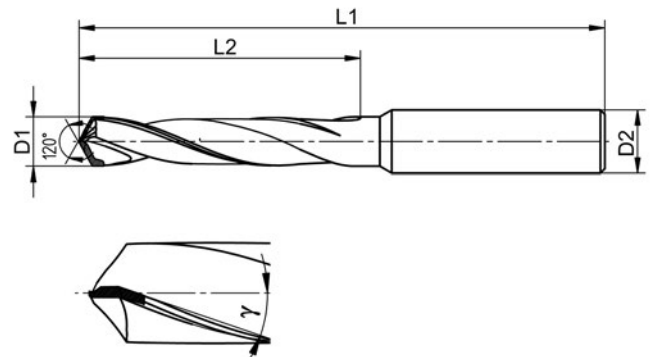
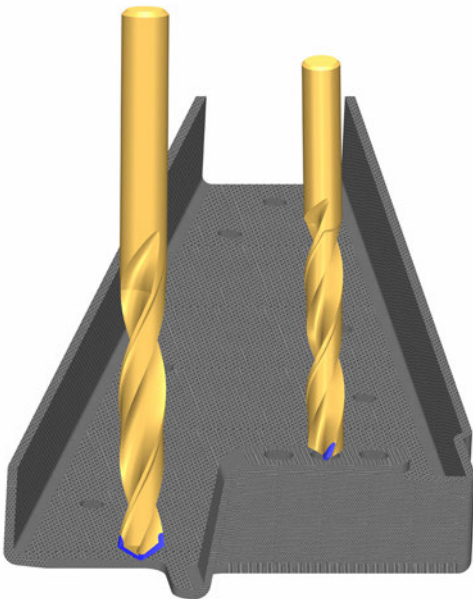

nach ISO 235
according to ISO 235

DIN 1897				DIN 338			
D1 / D2	L2	L1	Art. No.	D1 / D2	L2*	L1*	Art. No.
1,0	6	26	42401301	1,0	12	34	42401401
2,0	12	38	42401303	2,0	24	49	42401403
3,0	16	46	42401305	3,0	36	65	42401405
4,0	22	55	42401307	4,0	43	75	42401407
5,0	26	62	42401309	5,0	52	86	42401409
6,0	28	66	42401311	6,0	57	93	42401411

Bestellangaben: D-Spiralbohrer Typ S D1/D2 - L2 - L1 / Art. No.
Order Code: D-Twist Drill Type S D1/D2 - L2 - L1 / Art. No.

Bestellbeispiel: D-Spiralbohrer Typ S Ø1,0 - 6 - 26 / 42401301
Order Example: D-Twist Drill Type S Ø1,0 - 6 - 26 / 42401301

Andere Abmessungen und Ausführungen - auch Überlängen (L1/L2)* - maßgeschneidert nach Ihrer Vorgabe.
Custom-made dimensions - also excess lengths (L1/L2) - according to your specifications.*

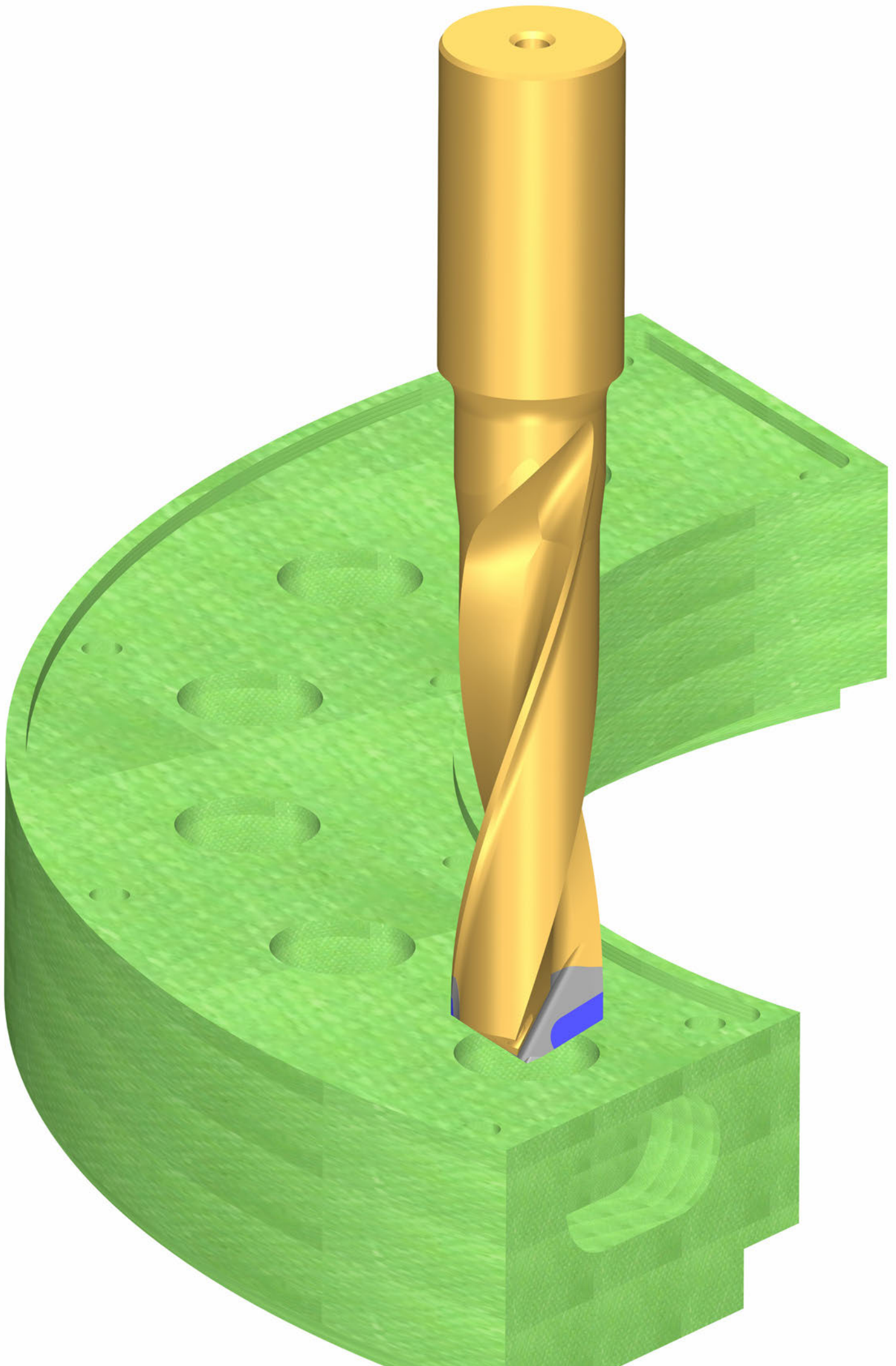

PKD-Spiralbohrer mit kombinierter PKD/HM-Schneide PCD Twist Drill with combined PCD/carbide cutting edge

Type XP

mit Innenkühlung **empfohlen für die** wirtschaftliche Bearbeitung bis 7xD
von GFK, CFK, Graphit, Composites, Grünkeramik
*with internal cooling **recommended for the economic processing of up to 7xD***
drilling depth of GRP, CFRP, graphite, composites, green ceramics

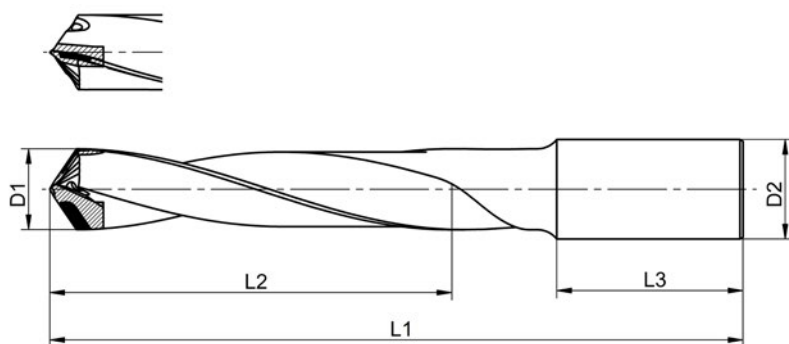

nach Werksnorm
according to factory standard

3 x D				5 x D			7 x D			Schaft/Shank DIN 6535-HA	
D1	L2	L1	Art. No	L2	L1	Art. No	L2	L1	Art. No	L3	D2
16,0	48	120	42402600	80	152	42402601	112	184	42402602	50	20
18,0	54	126	42402610	90	162	42402611	126	198	42402612	50	20
20,0	60	140	42402620	100	184	42402621	140	224	42402622	50	20
22,0	66	149	42402630	110	194	42402631	154	238	42402632	56	25
24,0	72	164	42402640	120	212	42402641	168	260	42402642	56	25
26,0	78	172	42402650	130	224	42402651	182	276	42402652	60	32
28,0	84	180	42402660	140	236	42402661	196	292	42402662	60	32
30,0	90	188	42402670	150	248	42402671	210	308	42402672	60	32
32,0	96	194	42402680	160	258	42402681	224	322	42402682	60	32
34,0	102	202	42402690	170	270	42402691	238	338	42402692	60	32
36,0	108	208	42402700	180	280	42402701	252	352	42402702	60	32
38,0	115	222	42402710	190	297	42402711	266	373	42402712	60	32
40,0	120	227	42402720	200	307	42402721	280	387	42402722	60	32

Bestellangaben: D-Spiralbohrer Typ XP D1 - L2 - L1 / Art. No.
Order Code: D-Twist Drill Type XP D1 - L2 - L1 / Art. No.

Bestellbeispiel: D-Spiralbohrer Typ XP Ø16,0 - 48 - 120 / 42402600
Order Example: D-Twist Drill Type XP Ø16,0 - 48 - 120 / 42402600

Weitere Schaftvarianten nach DIN 6535, Whistle Notch (-HE) oder Weldon (-HB) lieferbar.
Other types of shanks according to DIN 6535, Whistle Notch (-HE) or Weldon (-HB) available.

Andere Abmessungen und Ausführungen maßgeschneidert nach Ihrer Vorgabe
Custom-made dimensions according to your specifications

dreborid®-D

PKD-Spiralbohrer mit Dachformschneiden

PCD Twist Drill with solid self-centering cutting edges

Type W

mit Innenkühlung **empfohlen für** die wirtschaftliche Bearbeitung bis 5xD von GFK, CFK, Graphit, Composites

*with internal cooling **recommended for** the economic processing of up to 5xD drilling depth of GRP, CFRP, graphite, composites*

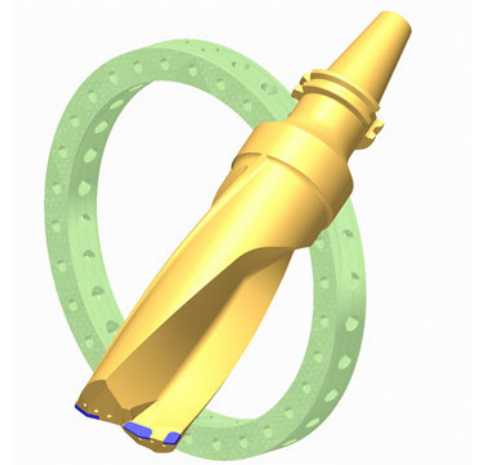

nach Werksnorm
according to factory standard

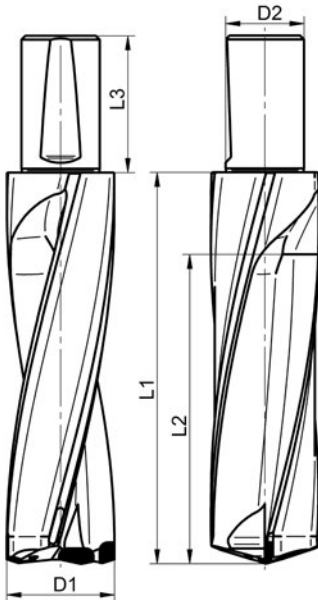

D1	L2	L1	L3	D2	Art. No.
30,0	90	115	60	32	42404500
35,0	105	135	60	32	42404510
40,0	120	155	60	32	42404520
45,0	135	175	70	40	42404530
50,0	150	195	70	40	42404540
55,0	165	215	70	40	42404550
60,0	180	235	70	40	42404560
65,0	195	255	70	40	42404570
70,0	210	275	70	40	42404580
75,0	225	295	70	40	42404590
80,0	240	315	70	40	42404600
85,0	240	315	70	40	42404610
90,0	240	315	70	40	42404620
95,0	240	315	70	40	42404630
100,0	240	315	70	40	42404640

Bestellangaben: D-Spiralbohrer Typ W D1 - L2 - L1 - A / Art.No.

Order Code: D Twist Drill Type W D1 - L2 - L1 - A / Art. No.

Bestellbeispiel: D-Spiralbohrer Typ W Ø70,0 - 210 - 275 - A / 42404580

Order example: D Twist Drill Type W Ø70,0 - 210 - 275 - A / 42404580



Weitere Schaftvarianten nach DIN 6535, Whistle Notch-HE oder Weldon HB lieferbar

Other shank dimensions according to DIN 6535, Whistle Notch HE or Weldon HB available

Andere Abmessungen und Ausführungen maßgeschneidert nach Ihrer Vorgabe
Custom-made dimensions according to your specifications

Nachschleifservice für alle PKD- und CBN-Werkzeuge

dreborid®-D

Hohlbohrer mit PKD-Wechsel-Schneidplatten

Hollow Drill with PCD indexable Inserts

Type WSH

empfohlen für die Bearbeitung von GFK, CFK und Kunststoffen allgemein
recommended for drilling GRP, CFRP and plastics in general

Für staubfreie Arbeitsplätze lieferbar
 mit effektiver Absaugeinrichtung (Patent angemeldet)

*For dust free application available
 with effective exhausting system (patent pending)*

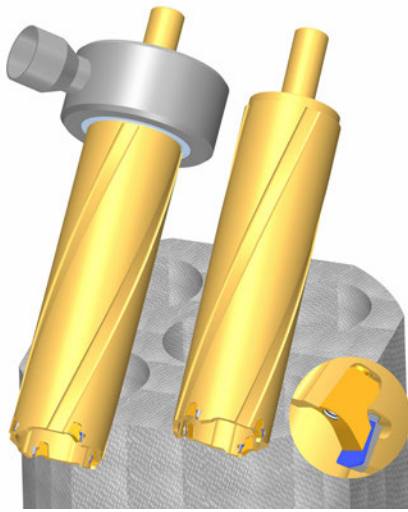

nach Werksnorm
 according to factory standard

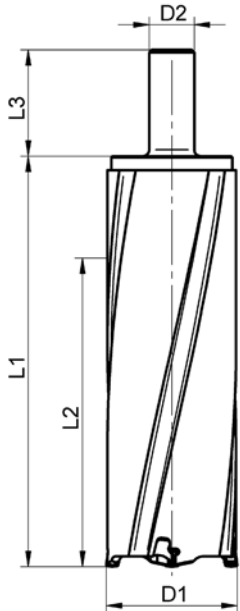

D1	L2	L1	L3	D2	Art. No.
30,0	90	115	60	32	42406019
35,0	105	135	60	32	42406020
40,0	120	155	60	32	42406021
45,0	135	175	70	40	42406022
50,0	150	195	70	40	42406023
55,0	165	215	70	40	42406024
60,0	180	235	70	40	42406025
65,0	195	255	70	40	42406026
70,0	210	275	70	40	42406027
75,0	225	295	70	40	42406028
80,0	240	315	70	40	42406029
85,0	240	315	70	40	42406030
90,0	240	315	70	40	42406031
95,0	240	315	70	40	42406032
100,0	240	315	70	40	42406033



PKD-Wechselschneidplatten *PCD indexable inserts*

ø Bereich Range	B	R	Art. No.
30 ≤ 40	4,50	0,4	42221571
40 ≤ 60	7,50	0,6	42221570
60 ≤ 120	10,50	0,8	42221432

Andere Abmessungen und Ausführungen maßgeschneidert nach Ihrer Vorgabe
 Custom-made dimensions according to your specifications

Resharpener Service for all PCD and CBN Cutting Tools

dreborid®-D

PKD-Zapfensenker

PCD Countersink

Einteilige Ausführung

Solid design

besonders empfohlen auch für dünnwandige Bauteile aus GFK, CFK und Kunststoffen allgemein

especially recommended also for thin-walled components made of GRP, CFRP and plastics in general

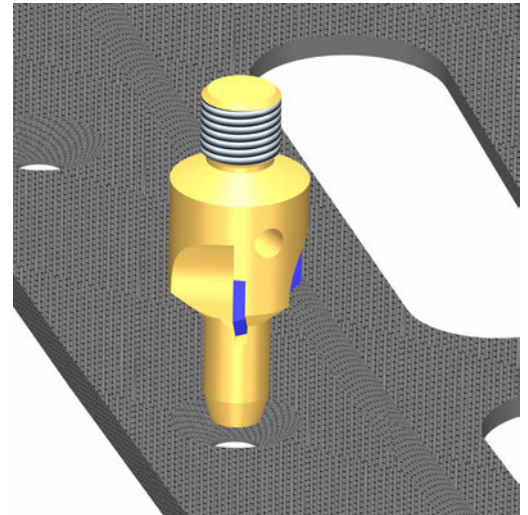
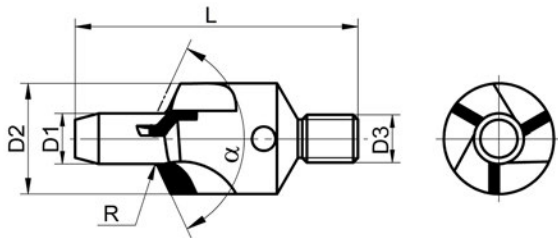

nach Werksnorm
according to factory standard

D1 mm / inch	a	R	D2	Z	D3	L	Art. No.
2,500 / 1/10	100	0,3	10	3	M6	30	42404200
3,200 / 1/8	100	0,3	10	3	M6	30	42404201
4,150 / 1/6	100	0,3	14	3	M8x1	36	42401520
4,810 / 1/5	100	0,6	14	3	M8x1	36	42401521
6,350 / 1/4	100	0,6	17	3	M8x1	36	42401522
7,940 / 1/3	100	0,9	19	3	M8x1	36	42401523
9,520 / 3/8	100	0,9	21	3	M8x1	36	42401524
11,120 / 4/9	100	1,2	25	3	M8x1	36	42401525
12,715 / 1/2	100	1,2	28	3	M8x1	36	42404220

Bestellangaben: D-Zapfensenker D1 - α - R - D2 - Z - D3 / Art.No.

Order Code: D-Countersink D1 - α - R - D2 - Z - D3 / Art.No.

Bestellbeispiel: D-Zapfensenker Ø2,5 - 100 - R0,3 - 10 - Z3 - M6 / 42404200

Order Example: D-Countersink Ø2,5 - 100 - R0,3 - 10 - Z3 - M6 / 42404200

Andere Abmessungen und Ausführungen maßgeschneidert nach Ihrer Vorgabe
Custom-made dimensions according to your specifications

Nachschleifservice für alle PKD- und CBN-Werkzeuge

dreborid®-D PKD-Zapfensenker

PCD Countersink

Zweiteilige Ausführung mit HM-Wechselzapfen
Two piece design with interchangeable carbide pilots

empfohlen für die Bearbeitung von GFK, CFK,
Kevlar und Kunststoffen allgemein

recommended for processing GRP, CFRP,
Kevlar and plastics in general

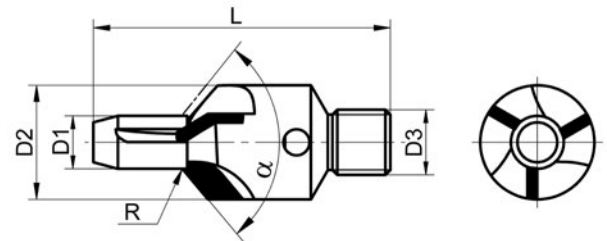
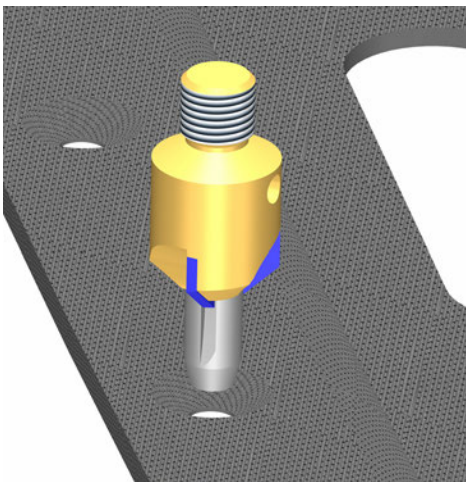

nach Werksnorm
according to factory standard

D1 mm / inch	α	R	D2	Z	D4	D3	L	Art. No.
4,150 / 1/6	100	0,3	14	3	2,6	M8x1	36	42404202
4,810 / 1/5	100	0,6	14	3	2,6	M8x1	36	42404205
6,350 / 1/4	100	0,6	17	3	4,0	M8x1	36	42404208
7,940 / 1/3	100	0,9	19	3	6,0	M8x1	36	42404211
9,520 / 3/8	100	0,9	21	3	6,0	M8x1	36	42404214
11,120 / 4/9	100	1,2	25	3	9,0	M8x1	36	42404217
12,715 / 1/2	100	1,2	28	3	9,0	M8x1	36	42405484

Wechselzapfenbereich
Range of interchangeable carbide pilots

D1	D4
3,8 - 5,0	2,6
5,1 - 7,0	4,0
7,1 - 9,9	6,0
10 - 15,0	9,0

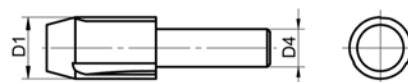

Bestellangaben: D-Zapfensenker D1 - α - R - D2 - Z - D3 / Art.No.

Order Code: D-Countersink D1 - α - R - D2 - Z - D3 / Art.No.

Bestellbeispiel: D-Zapfensenker Ø4,150 - 100 - R0,3 - 14 - Z3 - M8x1 / 42404202

Order Example: D-Countersink Ø4,150 - 100 - R0,3 - 14 - Z3 - M8x1 / 42404202

Andere Abmessungen und Ausführungen maßgeschneidert nach Ihrer Vorgabe
Custom-made dimensions according to your specifications

Resharpener Service for all PCD and CBN Cutting Tools

dreborid®-D PKD-Schaftfräser

PCD End Mill

Type SMS-C

empfohlen für die Bearbeitung von GFK, CFK, Graphit, Grünkeramik, Kunststoffen allgemein; Aluminium, Kupfer
recommended for milling GRP, CFRP, graphite, green ceramics, plastics in general; aluminium, copper

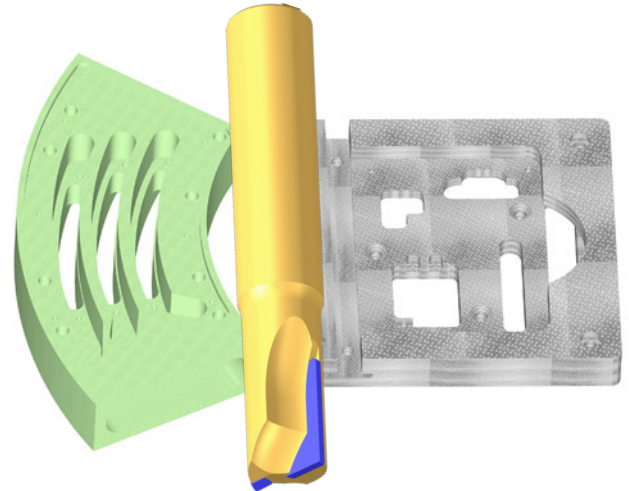

Type	Bestellcode Order Code	D1	D2	L	L1	L2	A	Art. No.
SMSC Mantel- und stirnschneidend <i>Side and face cutting</i>	D-SMSC-06-08	06	06	52	13	36	8	42401900
	D-SMSC-08-11	08	08	61	22	36	11	42401901
	D-SMSC-10-13	10	10	63	20	40	13	42401902
	D-SMSC-12-16	12	12	73	25	45	16	42401903
	D-SMSC-16-19	16	16	79	28	48	19	42401904
	D-SMSC-06-13	06	06	57	18	36	13	42401905
	D-SMSC-08-19	08	08	69	30	36	19	42401906
	D-SMSC-10-22	10	10	72	29	40	22	42401907
	D-SMSC-12-26	12	12	83	35	45	26	42401908
	D-SMSC-16-32	16	16	92	41	48	32	42401909

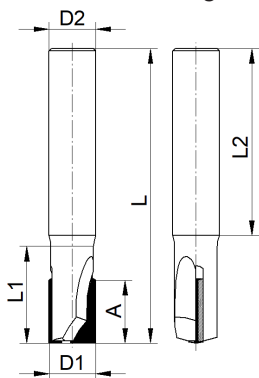

SMSAC
Mantel- und stirnschneidend
mit Achswinkel
*Side and face cutting with
shear angle*

D-SMSAC-06-08	06	06	52	13	36	8	42401910
D-SMSAC-08-11	08	08	61	22	36	11	42401911
D-SMSAC-10-13	10	10	63	20	40	13	42401912
D-SMSAC-12-16	12	12	73	25	45	16	42401913
D-SMSAC-16-19	16	16	79	28	48	19	42401914
D-SMSAC-06-13	06	06	57	18	36	13	42401915
D-SMSAC-08-19	08	08	69	30	36	19	42401916
D-SMSAC-10-22	10	10	72	29	40	22	42401917
D-SMSAC-12-26	12	12	83	35	45	26	42401918
D-SMSAC-16-32	16	16	92	41	48	32	42401919

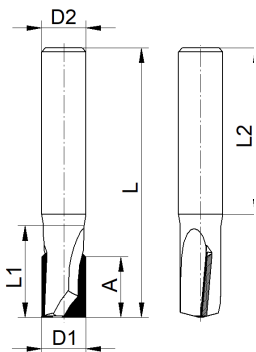

Andere Abmessungen und Ausführungen maßgeschneidert nach Ihrer Vorgabe
Custom-made dimensions according to your specifications

Nachschleifservice für alle PKD- und CBN-Werkzeuge

dreborid®-D
PKD-Schaftfräser
PCD End Mill
Type SMS-ECO

empfohlen für die Bearbeitung von Graphit, Grünkeramik, GFK, CFK und Kunststoffen allgemein
recommended for drilling graphit, green ceramics, GRP, CFRP and plastics in general

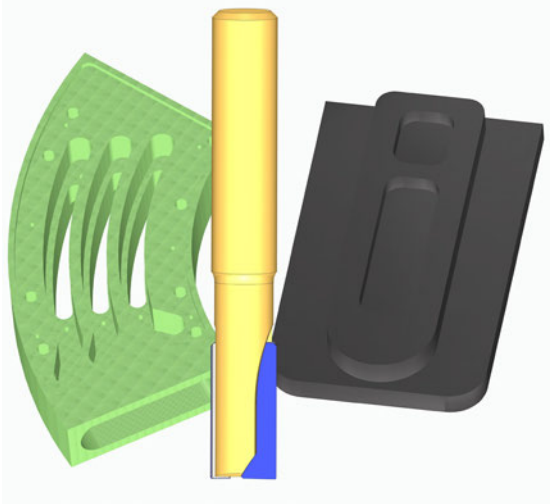

Type	Bestellcode Order Code	D1	D2	L	L1	L2	A	Art. No.
SMS ECO Mantel- und stirnschneidend <i>Side and face cutting</i>	D-SMS-06-10-ECO	6	6	52	20	30	10	42404534
	D-SMS-08-10-ECO	8	8	61	22	36	10	42402781
	D-SMS-10-10-ECO	10	10	63	20	40	10	42402782
	D-SMS-12-10-ECO	12	12	73	25	45	10	42402783
	D-SMS-08-20-ECO	8	8	69	30	36	20	42402784
	D-SMS-10-20-ECO	10	10	72	30	40	20	42402785
	D-SMS-12-20-ECO	12	12	83	35	45	20	42402786

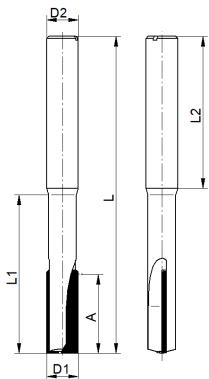

Andere Abmessungen und Ausführungen maßgeschneidert nach Ihrer Vorgabe
 Custom-made dimensions according to your specifications

dreborid®-D

PKD-Schafffräser mit positivem Spanwinkel

PCD End Mill with positive cutting angle

Type SMP-C

empfohlen für die Bearbeitung von empfindlichen und dünnwandigen Bauteilen aus GFK, CFK, Kevlar, Kunststoffen allgemein; Aluminium, Kupfer

recommended for milling sensitive and thin-walled components made of GRP, CFRP, Kevlar, plastics in general; aluminium, copper

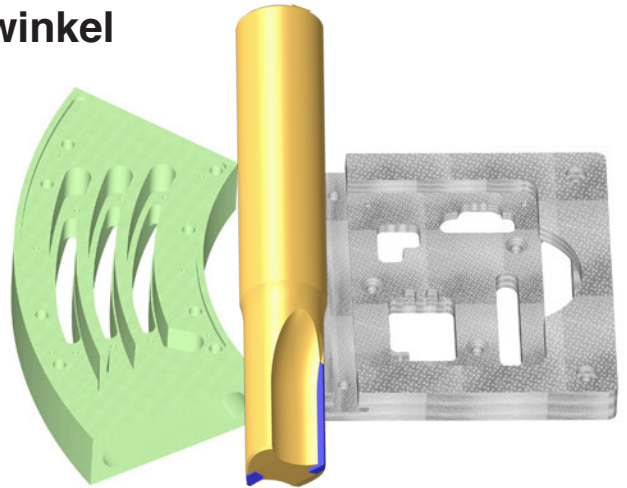

Type	Bestellcode <i>Order Code</i>	D1	D2	L	L1	L2	A	Art. No.
SMPC Mantelschneidend mit positivem Schnitt <i>Side cutting with positive cut</i>	D-SMPC-06-08	06	06	52	13	36	8	42402300
	D-SMPC-08-11	08	08	61	22	36	11	42402301
	D-SMPC-10-13	10	10	63	20	40	13	42402302
	D-SMPC-12-16	12	12	73	25	45	16	42402303
	D-SMPC-16-19	16	16	79	28	48	19	42402304
	D-SMPC-06-13	06	06	57	18	36	13	42402305
	D-SMPC-08-19	08	08	69	30	36	19	42402306
	D-SMPC-10-22	10	10	72	29	40	22	42402307
	D-SMPC-12-26	12	12	83	35	45	26	42402308
	D-SMPC-16-32	16	16	92	41	48	32	42402309

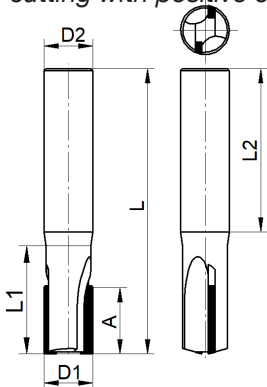

Andere Abmessungen und Ausführungen maßgeschneidert nach Ihrer Vorgabe
 Custom-made dimensions according to your specifications

Nachschleifservice für alle PKD- und CBN-Werkzeuge

dreborid®-D

PKD-Schaftfräser mit Wechsel-Achswinkel

PCD End Mill with shear cut Application

Type SMSWA

empfohlen für saubere Kantenbearbeitung beim Schruppen und Schlichten von Faserverbundwerkstoffen
recommended for fine finished edges for roughing and finishing operations of composite materials

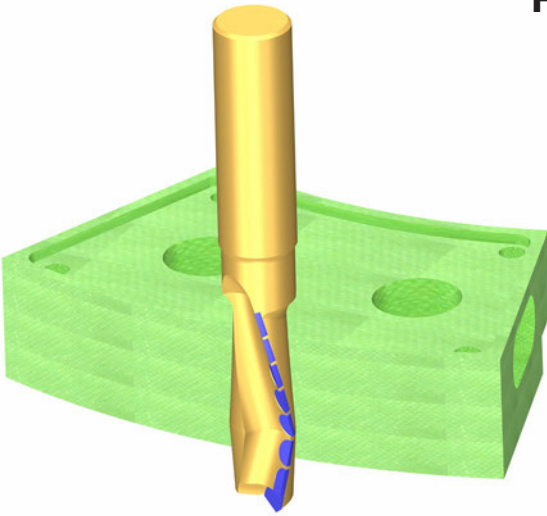

Type	Bestellcode <i>Order Code</i>	D1	D2	L	L1	L2	A	Art. No.
SMSWA Mantel- und stirnschneidend <i>Side and face cutting</i>	D-SMSWA-10-22	10	10	72	30	40	22	42401880
	D-SMSWA-12-26	12	12	83	36	45	26	42401881
	D-SMSWA-16-32	16	16	92	42	48	32	42401882
	D-SMSWA-20-38	20	20	104	52	50	38	42401883

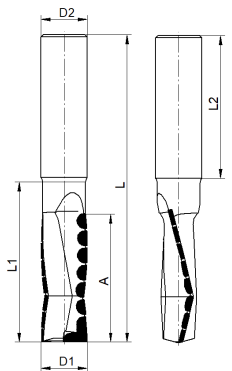

Andere Abmessungen und Ausführungen maßgeschneidert nach Ihrer Vorgabe
 Custom-made dimensions according to your specifications

dreborid®-D

PKD-Schafffräser mit großem Achswinkel

PCD End Mill with extreme shear cut

Type SMSXX

empfohlen für die Fertigbearbeitung von sensiblen Composite-Materialien, wie GFK, CFK; Aluminium, Kunststoffen allgemein

recommended for finishing sensitive composite materials like GRP, CFRP; aluminium, plastics in general

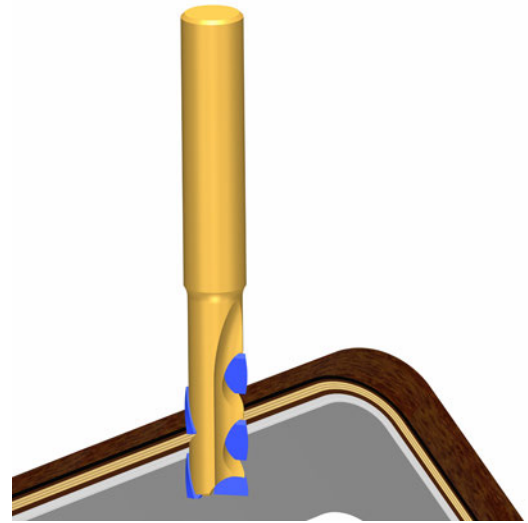

Type	Bestellcode Order Code	D1	D2	L	L1	L2	A	Art. No.
SMSXX Mantel- und stirnschneidend <i>Side and face cutting</i>	D-SMSXX-08-18	08	8	64	25	36	18	42401530
	D-SMSXX-10-18	10	10	68	25	40	18	42401531
	D-SMSXX-12-18	12	12	73	25	45	18	42401532
	D-SMSXX-16-25	16	16	83	32	48	25	42401533
	D-SMSXX-20-25	20	20	85	42	40	25	42401534

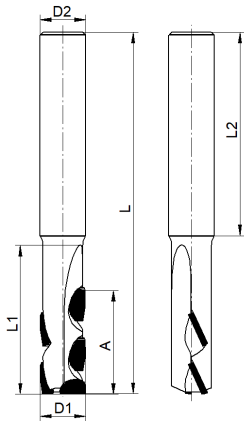

Andere Abmessungen und Ausführungen maßgeschneidert nach Ihrer Vorgabe
Custom-made dimensions according to your specifications

Nachschleifservice für alle PKD- und CBN-Werkzeuge

dreborid®-D
PKD-Vielzahn-Schaftfräser
PCD multiple End Mill
Type SMM

empfohlen zum Schlichten von Composites,
 wie GFK, CFK, Graphit, Grünkeramik
recommended for finishing composites
 like GFRP, CFRP, graphite, green ceramics

Auch mit Spanteiler lieferbar
Available also with chip breaker

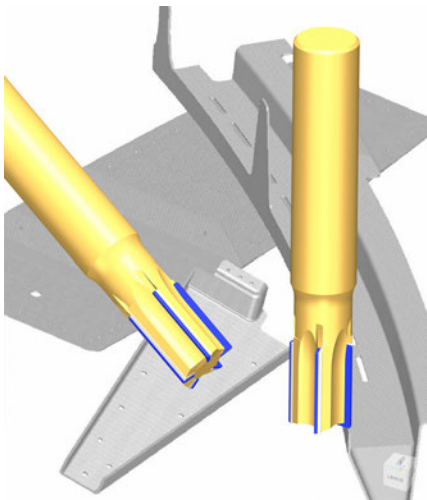

Type	Bestellcode Order Code	D1	D2	L	L1	L2	A	Z	Art. No.
	Standard-PKD-Schneiden (A)			Standard PCD Cutting edges (A)					
SMM Mantelschneidend Side cutting	D-SMM-08-11-03	08	08	61	22	36	11	03	42401850
	D-SMM-08-11-05	08	08	61	22	36	11	05	42401851
	D-SMM-10-13-03	10	10	63	20	40	13	03	42401852
	D-SMM-10-13-05	10	10	63	20	40	13	05	42401853
	D-SMM-12-16-03	12	12	73	25	45	16	03	42401854
	D-SMM-12-16-05	12	12	73	25	45	16	05	42401855
	D-SMM-16-19-03	16	16	79	28	48	19	03	42401857
	D-SMM-16-19-05	16	16	79	28	48	19	05	42401858
	Extra lange PKD-Schneiden (A)			Extra long PCD Cutting edges (A)					
	D-SMM-08-19-03	08	08	61	30	36	19	03	42401861
	D-SMM-08-19-05	08	08	61	30	36	19	05	42401862
	D-SMM-10-22-03	10	10	63	30	40	22	03	42401863
	D-SMM-10-22-05	10	10	63	30	40	22	05	42401864
	D-SMM-12-26-03	12	12	73	35	45	26	03	42401865
	D-SMM-12-26-05	12	12	73	35	45	26	05	42401866
	D-SMM-16-32-03	16	16	79	40	48	32	03	42401868
	D-SMM-16-32-05	16	16	79	40	48	32	05	42401869

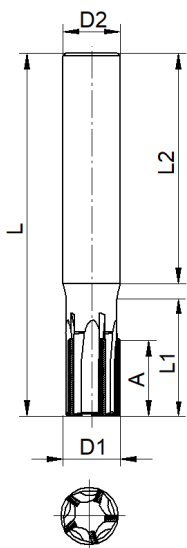

Andere Abmessungen und Ausführungen maßgeschneidert nach Ihrer Vorgabe
 Custom-made dimensions according to your specifications

Resharpening Service for all PCD and CBN Cutting Tools

dreborid®-D

PKD-Vielzahn-Schaftfräser mit Schrapp-Schneiden

PCD multiple End Mill for roughing

Type SMV

empfohlen zum Schruppen von dünnwandigen Bauteilen aus GFK, CFK, Kunststoffen allgemein

recommended for roughing of thin-walled components made of GRP, CFRP, plastics in general

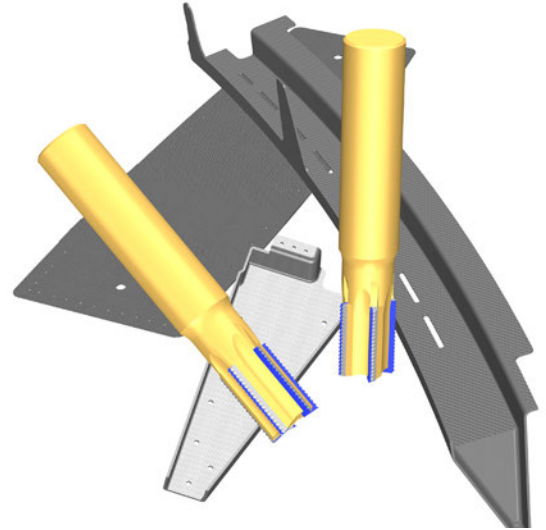

Type	Bestellcode Order Code	D1	D2	L	L1	L2	A	Z	Art. No.
	Standard-PKD-Schneiden (A)			Standard PCD Cutting edges (A)					
SMV Mantelschneidend Side cutting	D-SMV-08-11-03	08	08	61	22	36	11	03	42406040
	D-SMV-08-11-05	08	08	61	22	36	11	05	42400866
	D-SMV-10-13-03	10	10	63	20	40	13	03	42402688
	D-SMV-10-13-05	10	10	63	20	40	13	05	42402619
	D-SMV-12-16-03	12	12	73	25	45	16	03	42403433
	D-SMV-12-16-05	12	12	73	25	45	16	05	42402623
	D-SMV-16-19-03	16	16	79	28	48	19	03	42403435
	D-SMV-16-19-05	16	16	79	28	48	19	05	42403436
	Extra lange PKD-Schneiden (A)			Extra long PCD Cutting edges (A)					
	D-SMV-08-19-03	08	08	69	30	36	19	03	42403439
	D-SMV-08-19-05	08	08	69	30	36	19	05	42402624
	D-SMV-10-22-03	10	10	72	30	40	22	03	42403440
	D-SMV-10-22-05	10	10	72	30	40	22	05	42403441
	D-SMV-12-26-03	12	12	83	35	45	26	03	42403442
	D-SMV-12-26-05	12	12	83	35	45	26	05	42403443
	D-SMV-16-32-03	16	16	92	40	48	32	03	42403445
	D-SMV-16-32-05	16	16	92	40	48	32	05	42403446

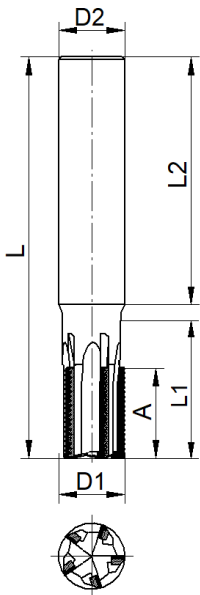

Andere Abmessungen und Ausführungen maßgeschneidert nach Ihrer Vorgabe
Custom-made dimensions according to your specifications

Nachschleifservice für alle PKD- und CBN-Werkzeuge

dreborid®-D
PKD-Vielzahn-Schaftfräser
PCD multiple End Mill
Type SMZ*

empfohlen zum Schruppen von Composites,
 wie GFK, CFK, Graphit, Grünkeramik
recommended for roughing composites
 like GRP, CFRP, graphite, green ceramics

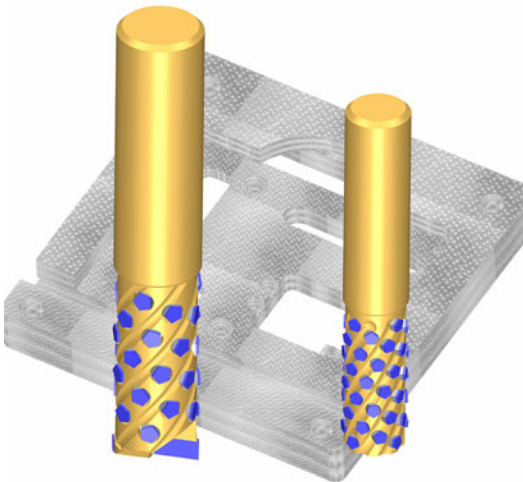

Type	Bestellcode Order Code	D1	D2	L	L1	L2	A	Art. No.
SMZ Mantelschneidend (ohne Stirnschneide) <i>Side grinding (without plunge cut)</i>	D-SMZ-08-19	08	08	69	30	36	19	42401800
	D-SMZ-10-22	10	10	72	29	40	22	42401801
	D-SMZ-12-26	12	12	83	35	45	26	42401802
	D-SMZ-16-32	16	16	92	41	48	32	42401803

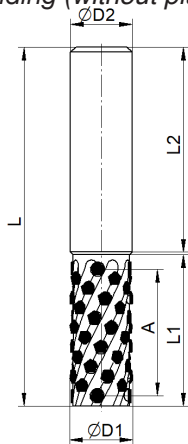

SMSZ
 Mantel- und stirnschneidend
 (mit Stirnschneide)
*Side and face cutting (with
 plunge cut)*

D-SMSZ-08-19	08	08	69	30	36	19	42401820
D-SMSZ-10-22	10	10	72	29	40	22	42401821
D-SMSZ-12-26	12	12	83	35	45	26	42401822
D-SMSZ-16-32	16	16	92	41	48	32	42401823

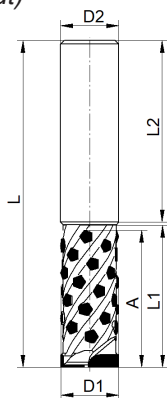

Andere Abmessungen und Ausführungen maßgeschneidert nach Ihrer Vorgabe
 Custom-made dimensions according to your specifications

* Deutschland Patent 10 2005 044 015
 USA-Patent 7 367 753 B2
 * German Patent 10 2005 044 015
 US Patent 7 367 753 B2

dreborid®-D

PKD » dia-compact«-Monoblock-Einschraubfräser mit Innenkühlung

PCD » dia-compact« Monoblock Milling Cutter for adapting with internal cooling

Type MBC-E

empfohlen für die Bearbeitung von GFK, CFK, Graphit, Grünkeramik, Kunststoffen allgemein, Aluminium

recommended for milling GRP, CFRP, graphite, green ceramics, plastics in general, aluminium

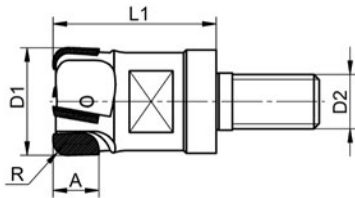
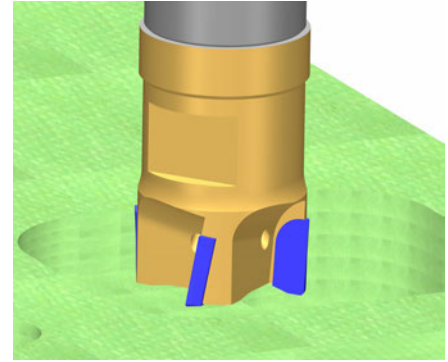

Bestellcode Order Code	D1	D2	R	L1	A	Z	Art. No.
D-MBC-E0-90-16-08-Z3-R2-M8	16	M8	2	25	8	3	42501300
D-MBC-E0-90-20-08-Z4-R2-M8	20	M10	2	30	8	4	42501301
D-MBC-E0-90-25-08-Z4-R3-M12	25	M12	3	35	8	4	42501302
D-MBC-E0-90-32-08-Z6-R4-M16	32	M16	4	40	8	6	42501303

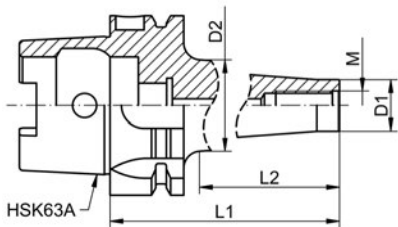

Aufnahme Adapter HSK

Bestellcode Order Code	D1	D2	L1	L2	M	Art. No.
HSK63A-51-M8	13,8	15	51	25	8	42510500
HSK63A-101-M8	13,8	25	101	75	8	42510501
HSK63A-51-M10	18	23	51	25	10	42510502
HSK63A-101-M10	18	30	101	75	10	42510503
HSK63A-126-M10	18	35	126	100	10	42510504
HSK63A-151-M12	21	43	151	125	12	42510507
HSK63A-176-M16	29	48	176	150	16	42510512

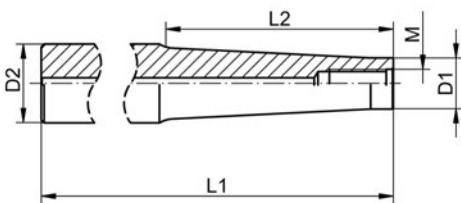

Aufnahme Zylinderschaft
Adapter cylindrical

16h6-80-M8	13	16	135	80	8	42510520
16h6-100-M8	13	16	155	100	8	42510521
16h6-120-M8	13	16	175	120	8	42510522
20h6-100-M10	18	20	160	100	10	42510523
20h6-140-M10	18	20	200	140	10	42510524
25H6-100-M12	21	25	165	100	12	42510525
32H6-150-M16	29	32	220	150	16	42510527

Bestellbeispiel: D-MBC-E0-90-25-8-Z4-R4-M12 + Aufnahme-Code
(auch mit HSK 80 A / HSK 100 A und SK 40 / SK 50 lieferbar)

Example for ordering: D-MBC-E0-90-25-8-Z4-R4-M12 + Adapter Code
(also available with HSK 80 A / HSK 100 A and SK 40 / SK 50)

Andere Abmessungen und Ausführungen maßgeschneidert nach Ihrer Vorgabe
Custom-made dimensions according to your specifications

Nachschleifservice für alle PKD- und CBN-Werkzeuge

dreborid®-D

PKD »dia-compact« - Monoblock-Plan-/Eckfräser

PCD »dia-compact« Monoblock Face and square shoulder Milling Cutter

Type MBC-X

empfohlen für die Bearbeitung von GFK, CFK, Graphit, Grünkeramik

recommended for milling GRP, CFRP, graphite, green ceramics

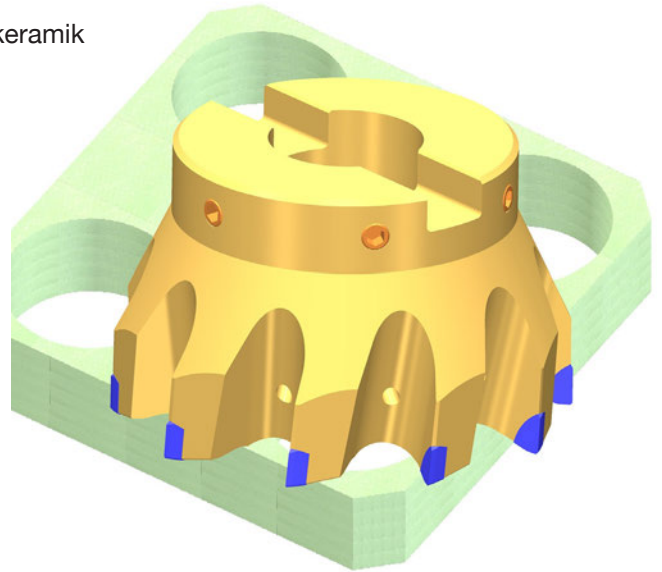
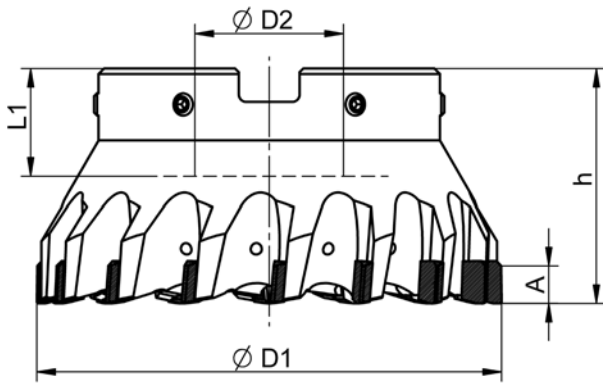

Type	Bestellcode Order Code	D1	h	A	D2	L1	Z	Art. No.
MBC-X 90	D-MBC-X0-90-040-08-Z5	40	40	8	16	21	5	42505110
Anstellwinkel 90° Lead Angle	D-MBC-X0-90-050-08-Z6	50	40	8	16	21	6	42505210
	D-MBC-X0-90-063-08-Z8	63	45	8	22	21	8	42505310
	D-MBC-X0-90-080-10-Z10	80	50	10	27	23	10	42505410
	D-MBC-X0-90-100-10-Z12	100	50	10	32	26	12	42505510
	D-MBC-X0-90-125-10-Z16	125	63	10	40	29	16	42505610
	D-MBC-X0-90-160-10-Z20	160	63	10	40	29	20	42505710
	D-MBC-X0-90-200-13-Z24	200	63	13	40	29	24	42505810
MBC-X 75	D-MBC-X0-75-040-08-Z5	40	40	8	16	21	5	42500110
Anstellwinkel 75° Lead Angle	D-MBC-X0-75-050-08-Z6	50	40	8	16	21	6	42500210
	D-MBC-X0-75-063-08-Z8	63	45	8	22	21	8	42500310
	D-MBC-X0-75-080-10-Z10	80	50	10	27	23	10	42500410
	D-MBC-X0-75-100-10-Z12	100	50	10	32	26	12	42500510
	D-MBC-X0-75-125-10-Z16	125	63	10	40	29	16	42500610
	D-MBC-X0-75-160-10-Z20	160	63	10	40	29	20	42500710
	D-MBC-X0-75-200-13-Z24	200	63	13	40	29	24	42500810

Fräser für Aufnahme nach ISO 6462

Cutter for adapter according to ISO 6462

Andere Abmessungen und Ausführungen maßgeschneidert nach Ihrer Vorgabe
Custom-made dimensions according to your specifications

Nachschleifservice für alle PKD- und CBN-Werkzeuge

dreborid®

»dia-compact«-Plan-Eckfräser mit Kassetten »dia-compact« face and square shoulder Milling Cutter with cartridges

empfohlen für Schrupp-, Schlicht- und Feinschlichtbearbeitung
von GFK und Kunststoffen

*recommended for rough, finish and super finish processing
of GRP and plastics*

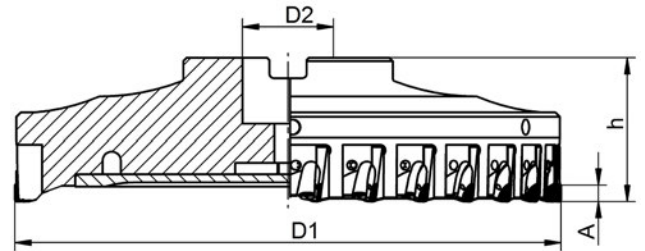

	Bestellcode Order Code	Baumaße Dimensions					Art. No.
		D1	h	A	D2	Z	
für Kassetten-Größe 2 for cartridge size 2	D-CFM-90-125-6-Z14	125	63	6	40	14	42400001
	D-CFM-90-160-6-Z16	160	63	6	40	16	42400003
für Kassetten-Größe 1 for cartridge size 1	D-CFM-90-200-10-Z16	200	63	10	40	16	42404700
	D-CFM-90-220-10-Z18	220	63	10	40	18	42404702
	D-CFM-90-240-10-Z20	240	63	10	40	20	42404704
	D-CFM-90-260-10-Z22	260	63	10	40	22	42404706
	D-CFM-90-280-10-Z24	280	63	10	40	24	42404708
	D-CFM-90-300-10-Z24	300	63	10	40	24	42404710
	D-CFM-90-315-10-Z28	315	63	10	40	28	42404712
	D-CFM-90-350-10-Z30	350	63	10	40	30	42404714
	D-CFM-90-375-10-Z32	375	63	10	40	32	42404716
	D-CFM-90-400-10-Z34	400	63	10	40	34	42404718

Der Bestellcode mit Art. No. beinhaltet den kompletten Fräser ohne PKD Kassetten.

Die Ausführung der Kassetten wählen Sie auf Seite 28.

The order code with Art. No. includes the complete milling cutter without PCD cartridge.

For the version of the cartridges please see page 28.

Hinweis: »dia-compact-Plan-Eckfräser mit Kassetten sind für die Aufnahme in Ihrem Adapter vorgewuchtet.

Alternativ liefern wir den Adapter Ihrer Wahl komplett montiert und feinstgewuchtet.

Note: »dia-compact« CFM face milling cutters are pre-balanced for the tool attachment in your adapter.

Alternatively we supply the adapter of your choice completely mounted and precision-balanced.

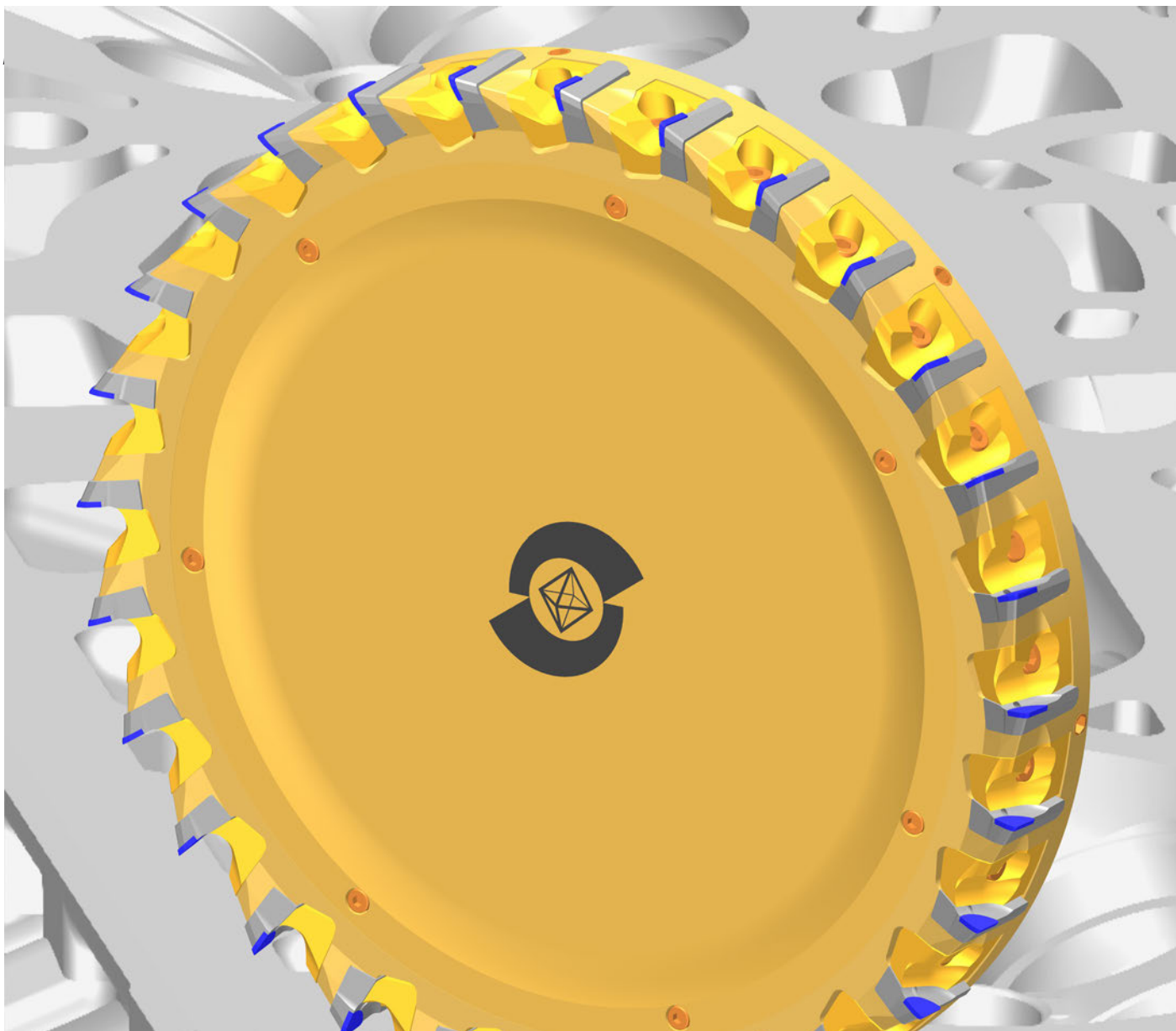

PKD-Kassetten für Plan-Eckfräser

PCD Cartridges for face and square shoulder milling cutter

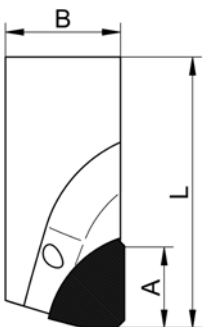
	Bestellcode <i>Order Code</i>	Baumaße <i>Dimensions</i>			Art. No.
		B	L	A	
	Größe <i>Size</i> 1				
	D-CRC 17 x 29-A10/P	17	29	10	42401200
	D-CRC 17 x 29-A10/F	17	29	10	42401202
	D-CRC 17 x 29-A10/FF	17	29	10	42401204
	Größe <i>Size</i> 2				
	D-CRC 10 x 24-A6/P	10	24	6	42401201
	D-CRC 10 x 24-A6/F	10	24	6	42401203
	D-CRC 10 x 24-A6/FF	10	24	6	42401205

P= Standard-Kassette
Standard cartridge

F= Schlicht-Kassette
Finish cartridge

FF= Feinschlicht-Kassette
Super finish cartridge

Nachschleifservice für alle PKD- und CBN-Werkzeuge

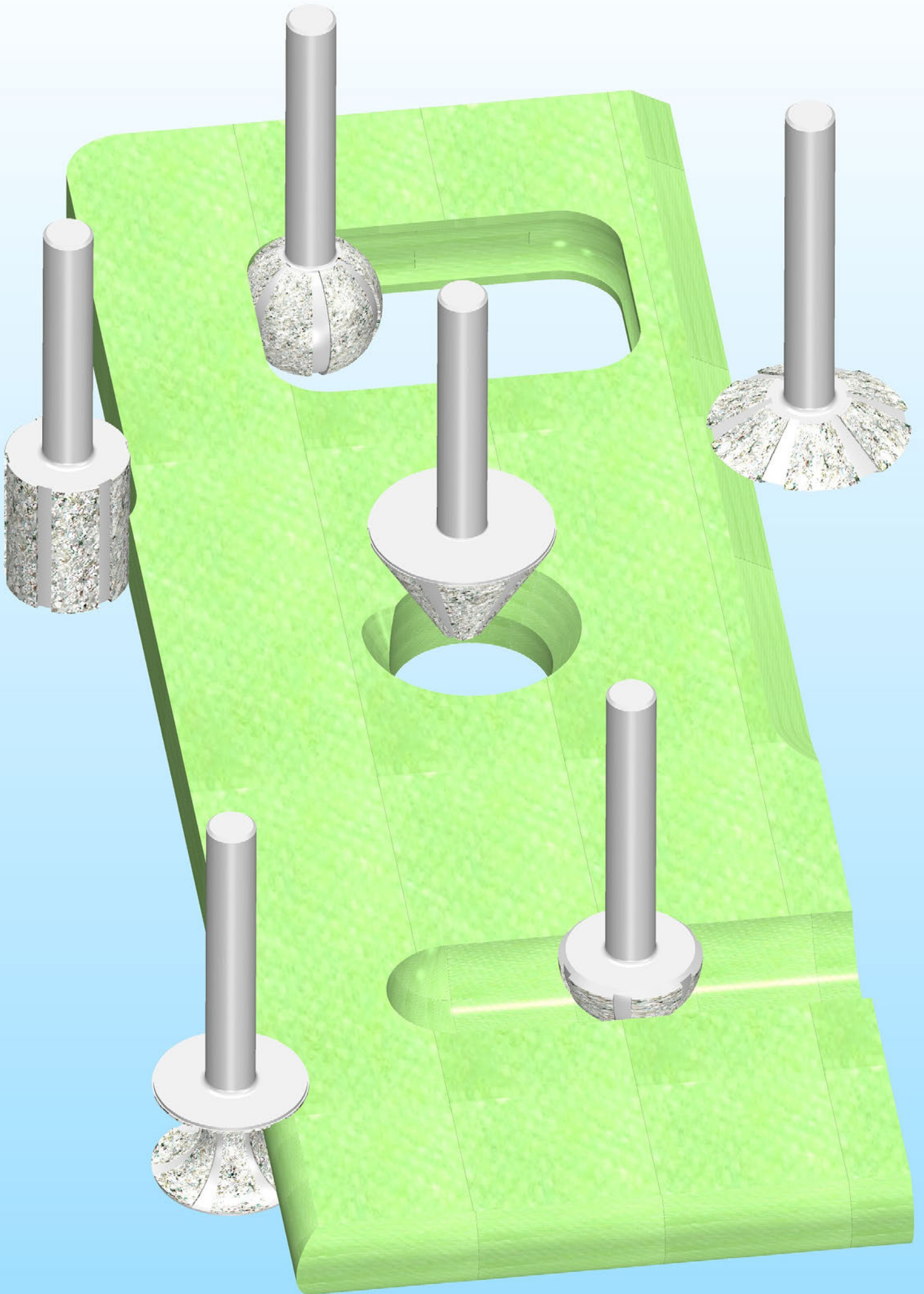

Diamant-Trennscheiben G-SY galvanische Bindung

Diamond cutting disc G-SY - electroplated bond

zur Bearbeitung von GFK - CFK - Duroplasten
for processing GRP - CFRP - Duroplast

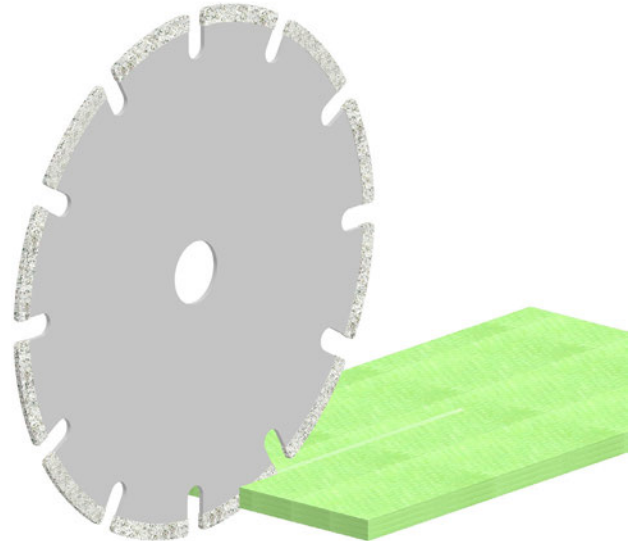

Form LT - geschlossener Rand
closed rim

Form LT-U - gezahnter Rand
interrupted rim

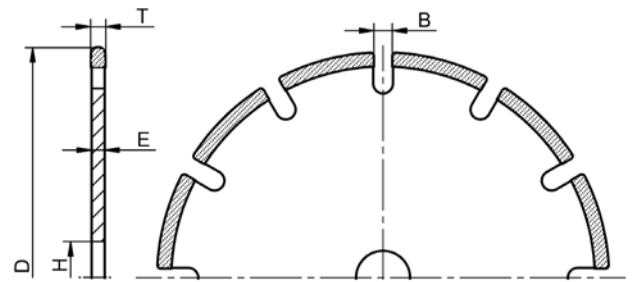
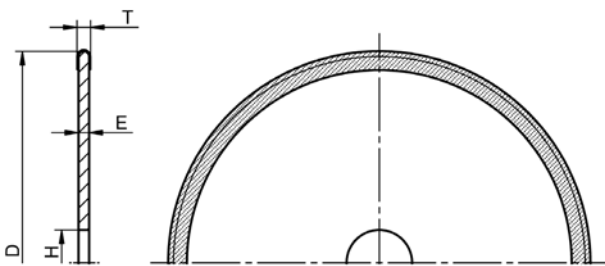

Diamantkörnungen: Diamond grit size:	D76-D91-D126-D151-D181-D213-D252-D301-D356-D427-D501-D601-D711		
Bestellangaben:	a) Form LT oder LT-U b) Durchmesser D c) Schnittbreite T d) Bohrung H e) Diamantkörnung	Order code:	a) form LT or LT-U b) diameter D c) cutting width T d) bore size H e) diamond grit size

Die Eigenart der galvanischen Bindung bewirkt, dass sehr große Spanräume für schnelles Trennen mit großer Abtragsleistung vorhanden sind.

The advantage of the electroplated bond is the great chip space for fast cutting and a high removal rate.

Lach-Diamant-Trennscheiben G-SY - Einsatz überwiegend im Trockenschliff.

LACH Diamond cutting discs G-SY - mainly used for dry grinding.

Diamant-Entgrat- und Fräswerkzeuge G-SY galvanische Bindung

Diamond deburring and milling tools G-SY - electroplated bond

zur Bearbeitung von GFK - CFK - Duroplasten
for processing GRP - CFRP - Duroplast

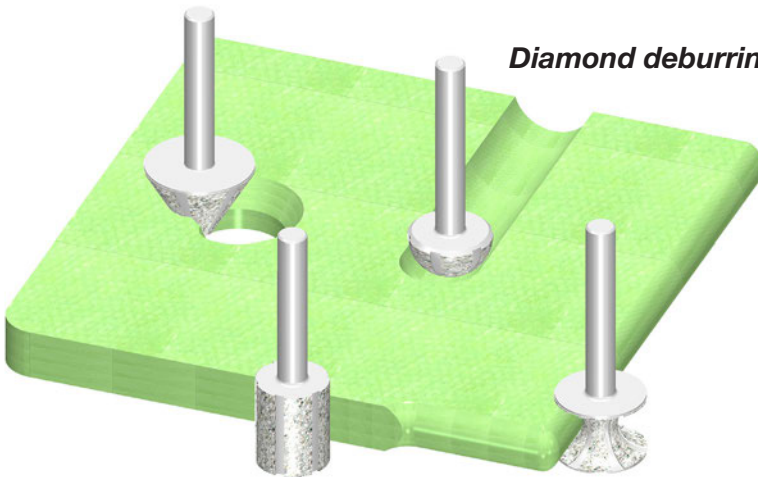

Form

ES-1	ES-2	ES-3	ES-4
------	------	------	------

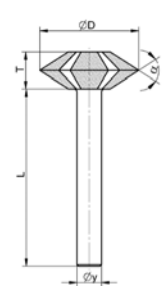
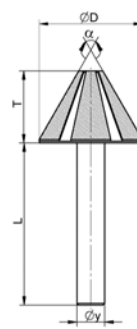
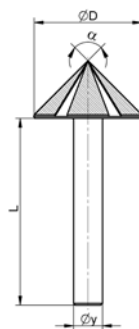
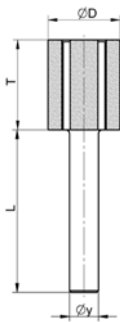

Form

ES-5	ES-6	ES-7	ES-8
------	------	------	------

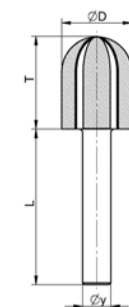
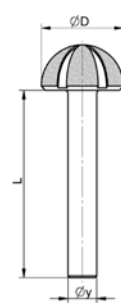
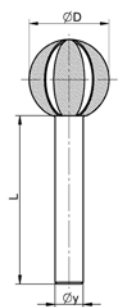

Andere Formen nach Maßangabe oder Skizze lieferbar. Other forms available.

Diamantkörnungen	Diamond grit size	Bestellangaben	Order code
Feinbearbeitung D 151 Vor- und Grobbearbeitung D 356 (andere Diamantkörnungen lieferbar)	finishing D 151 rough machining D 356 (other diamond grit sizes available)	a) Form b) Abmessungen c) Diamantkörnung	a) form b) dimension c) diamond grit size

LACH-Diamant-Entgrat- und Fräswerkzeuge werden im Trockenschliff eingesetzt.
LACH Diamond deburring and milling tools for dry grinding.

Diamant-Hohlbohrer G-SY galvanische Bindung

Diamond hollow drill G-SY electroplated bond

zur Bearbeitung von GFK - CFK - Duroplasten
for processing GRP - CFRP - Duroplast

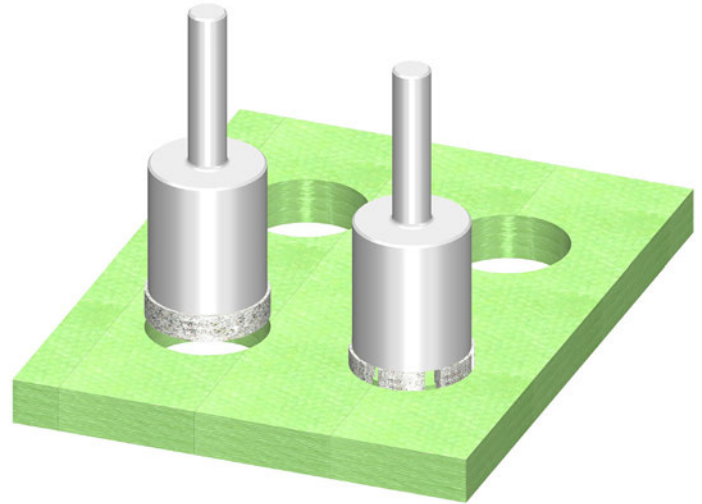

Form A
geschlossener Rand
closed rim

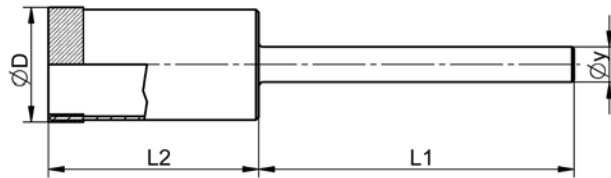

Form B
gezahnter Rand
serrated rim

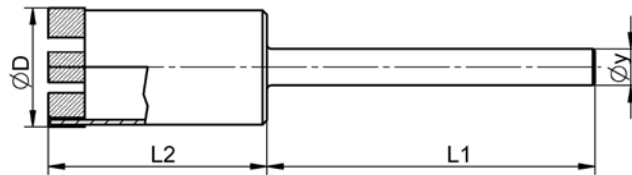

Diamantkörnungen: D356 - D427
Diamond grit size:

Zusätzlich auch mit:
seitlichen Auswurfschlitz
oder automatischem Auswerfer
oder auswechselbarem HSS-Zentrierbohrer

Additional with:
lateral slots
or automatic throw off
or changeable HSS centre drill

Bestellangaben:
a) Form A oder B
b) Außen- \varnothing D
c) Bohrtiefe L2
d) Anschluß \varnothing Y x L1 oder R1/2"
e) Diamantkörnung

Order code:
a) form A or B
b) external \varnothing D
c) drilling depth L2
d) adapter \varnothing Y x L1 or R 1/2"
e) diamond grit size

LACH-Diamant-Hohlbohrer G-SY werden ohne Kühlung eingesetzt.
LACH diamond hollow drills G-SY are used without coolant.

Diamant-Schaftfräser G-SY galvanische Bindung

Diamond router bit G-SY - electroplated bond

zur Bearbeitung von GFK - CFK - Duroplasten
for processing GRP - CFRP - Duroplast

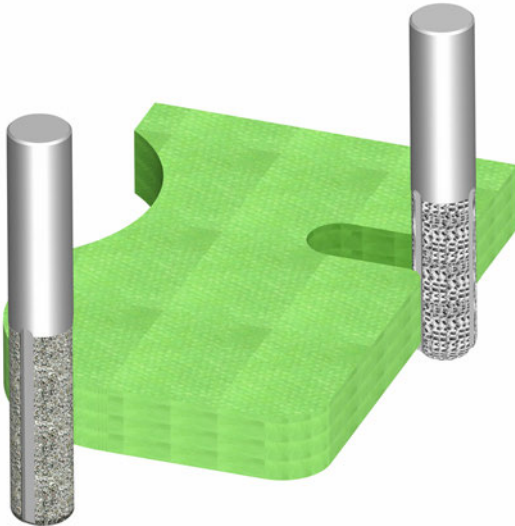

Form A
Vollbelag
closed coat

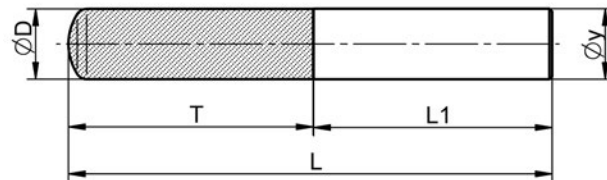

Form B
Segmentbelag
interrupted coat

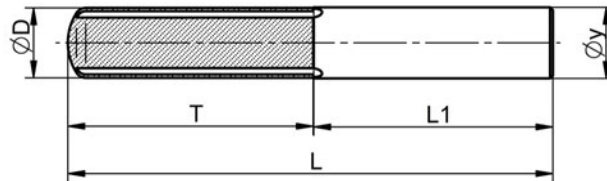

Diamantkörnungen: Diamond grit size:	fein <i>fine</i> D 151 D 181 D 213	mittel <i>medium</i> D 252 D 301	grob <i>rough</i> D 356 D 427
Bestellangaben:	a) Form A oder B b) Außen-Ø D c) Belaglänge T d) Gesamtlänge L e) Schaft Ø Y f) Schaftlänge L1 g) Diamantkörnung	Order code:	a) form A or B b) outside Ø D c) length of coat T d) total length L e) shank Ø Y f) length of shank L1 g) diamond grit size

LACH-Diamant Schaftfräser werden im Trockenschliff eingesetzt.
LACH Diamond router bits for dry grinding.

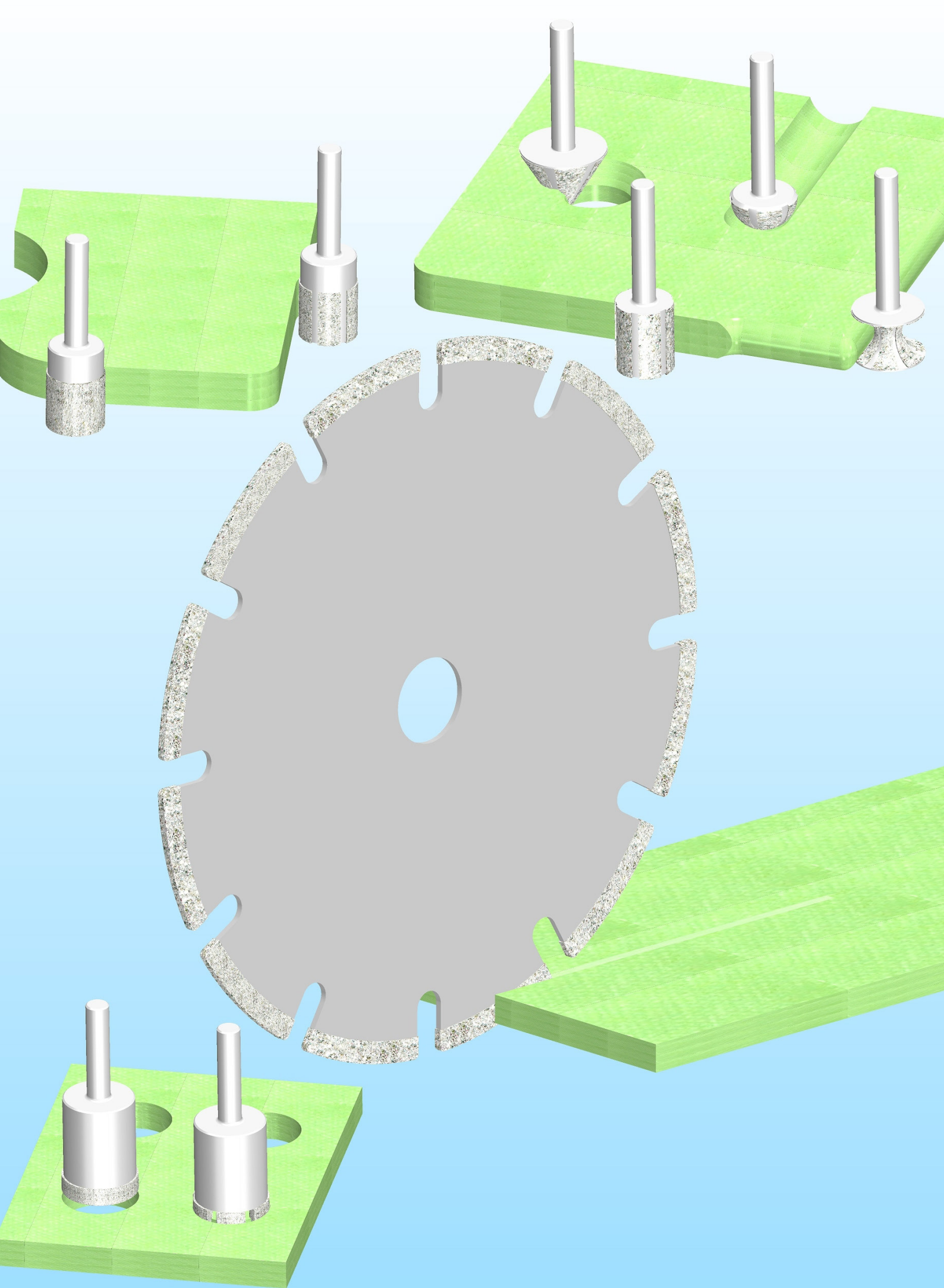

LACH-Diamant- und CBN-Fertigungsprogramm

Schleifen von Hartmetall und Keramik	Diamant-Schleifscheiben u. -Stifte in Kunststoff-, Metall-, Keramik- und Galvanik-Bindungen
Schleifen von HSS und gehärteten Stählen	CBN-Schleifscheiben und -Stifte in Kunststoff-, Metall-, Keramik- und Galvanik-Bindungen
Drehen, Bohren, Fräsen von NE-Metallen, gehärteten Stählen, Guss und HSS	dreborid®- polykristalline Diamant- und CBN-Zerspanungswerkzeuge
Abrichten von Schleifscheiben	Einzel-Abrichtdiamanten, geschliffene Profil- und Kopier-Diamanten, Vielkorn-Abrichter, Abrichtplatten und Aggregate, Präzisions-Diamant-Abrichtrollen, drebojet®-Diamant-Fräs-Abrichtrollen, Rohdiamanten - auch zur Vorlage - aus eigenen Importen
Feilen, Entgraten, Trennen	Diamant-Feilen, Diamant-Entgratungswerkzeuge, Diamant-Trennscheiben für Kunststoffe, Duroplaste, HM-Grünlinge
Läppen und Polieren	Diamant-Pasten und Diamant-Spray-MF-Programm
Fräsen, Profilieren, Nuten, Sägen aller Holzwerkzeuge und Kunststoffe und von Laminatfußboden	DIA-Werkzeugprogramm für alle Holz-, Kunststoff-, GFK-, CFK-Verarbeiter
PKD-Diamant-Schleifmaschinen	für Herstellung und Nachschärfen aller polykristallinen Diamant-Werkzeuge
Service-Leistungen	Umfassen und Nachschleifen in eigener Diamant-Schleiferei von Einzel-Abrichtdiamanten, Profil- und Kopierdiamanten, Tastdiamanten, Naturdiamanten, Natur-Drehdiamanten, Nachschärfdienste - bundesweit - polykristalline Diamant- und CBN-Werkzeuge, Nachbelegung galvanisch gebundener Diamant- und CBN-Werkzeuge, Beschichtung von Verschleißteilen

LACH Diamond and CBN Manufacturing Programme

Grinding of carbide and ceramics	Diamond grinding wheels and pins in resin, metal, vitrified and electroplated bonds
Grinding of HSS and hardened steels	CBN grinding wheels and pins in resin, metal, vitrified and electroplated bonds
Turning, boring, milling of non-ferrous metals, hardened steels, cast iron and HSS	dreborid®- polycrystalline diamond and CBN cutting tools
Dressing of grinding wheels	Single point diamond dressers, profile dressers, multi point diamond dressers, dressing plates, precision diamond dressing rolls, drebojet® diamond mill dressing rolls, natural diamonds from own imports
Filling, deburring, cutting-off	Diamond files, diamond deburring tools, diamond cut off grinding wheels for plastics, duroplasts, sintered carbide
Lapping and polishing	Diamond lapping compounds and diamond spray MF programme
Milling, profiling, grooving, sawing of all wood materials and plastics and laminate flooring	Diamond tool programme for wood, plastics, CFRP, GRP
PCD diamond grinding machines	for manufacturing and resharping of all polycrystalline diamond tools
Service	Resetting® and resharping of single point diamond dressers, profile and copy diamonds, diamonds for probe, natural diamond turning tools, resharping service for polycrystalline diamond and CBN tools, recoating of diamond and CBN tools with electroplated bond, coating of wear parts



Stammwerk / Headquarter Hanau/Frankfurt/M.



Werk Sachsen / Plant Saxonia Lichtenau/Chemnitz



Lach Diamond Inc., Grand Rapids, Michigan, USA

JAKOB LACH GmbH & Co. KG
 Donaust. 17 · D-63452 Hanau
 Telefon +49-61 81-103 0
 Fax +49-61 81 - 103 860
www.lach-diamant.de
office@lach-diamant.de

