

LACH DIAMANT®

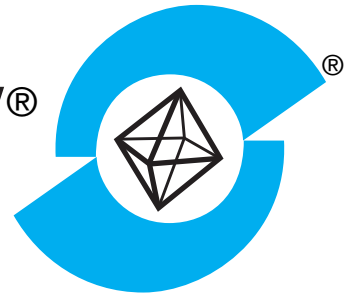

Donaustr. 17 · D-63452 Hanau
Tel. 49 61 81 103-941 · Fax 49 61 81 103-860
office@lach-diamant.de · www.lach-diamant.de

CBN-Präzisions-Schleifstifte und Schleifscheiben **G-MX 500**

CBN Precision Grinding Pins
and Wheels

Ab Lager lieferbar
available from stock



für gehärtete Stähle

- ◆ **scharf angreifend**
- ◆ **hohe Abtragsleistung**
- ◆ **lange Standzeiten**

for hardened steels

- ◆ **very sharp cutting action**
- ◆ **high removal rate**
- ◆ **high wear resistance**

LACH-CBN-Präzisions-Schleifscheiben-G-MX 500



CBN Precision Grinding Wheels G-MX 500

In galvanischer Spezial-Bindung für das Innenschleifen von HSS und gehärteten Stählen ab HRc 55.
Ausführung mit zylindrischer Bohrung für Durchgangsschleifen (auch für Sacklochbohrungen lieferbar)
Standardkörnung B151

Electroplated bond for ID Grinding of HSS and hardened steels starting at HRc 55.
Hole type grinding wheel for through feed grinding (also available for blind hole grinding)
Standard grit size B151

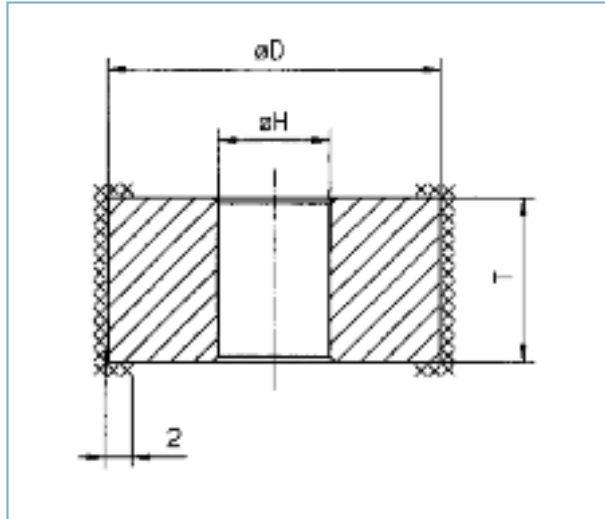

Artikel-Nr. Article No.	D mm	T mm	H mm	Preis EURO/Stück Unit Price EURO
333 15 001	10	10	6	23,50
333 15 002	12	10	6	30,50
333 15 003	15	10	6	34,80
333 15 004	18	10	8	38,50
333 15 005	20	10	8	42,00
333 15 006	25	10	13	51,90
333 15 007	30	10	13	56,80
333 15 008	35	10	20	61,60
333 15 009	40	10	20	67,70
333 15 010	45	10	20	71,40
333 15 011	50	10	20	77,60
333 15 012	60	10	20	88,80
333 15 013	75	10	20	101,40

Mengenrabatte auf Anfrage / Quantity discount on request

LACH-CBN-Präzisions-Schleifstifte G-MX 500



CBN Precision Grinding Pins G-MX 500

In galvanischer Spezial-Bindung für das Innenschleifen von HSS und gehärteten Stählen ab HRc 55
Standardkörnung B151

Electroplated bond for ID Grinding of HSS and hardened steels starting at HRc55
Standard grit size B151

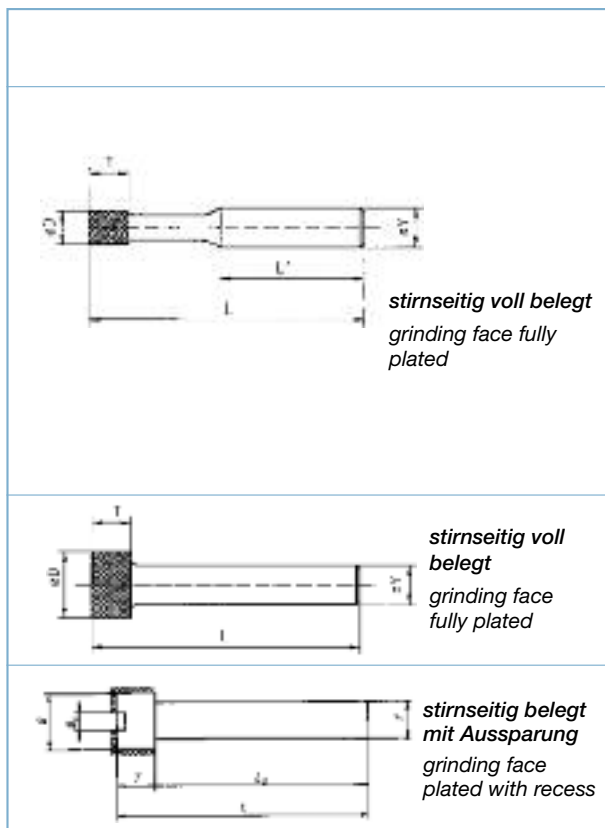

Artikel-Nr. Article No.	D mm	T mm	Y mm	L mm	L ₁ mm	Preis EURO/Stück Unit Price EURO
331 15 001	0,5	2	3	40	33	11,00 (nur /only B91)
331 15 002	0,6	4	3	40	33	10,90 (nur /only B91)
331 15 003	0,7	4	3	40	33	10,20
331 15 004	0,8	4	3	40	31	10,20
331 15 005	0,9	4	3	40	31	9,30
331 15 006	1,0	4	3	40	31	9,30
331 15 007	1,2	4	3	40	28	9,30
331 15 008	1,5	4	3	40	28	9,50
331 15 009	1,7	4	3	40	28	9,60
331 15 010	2,0	4	3	40	24	9,60
331 15 011	2,5	4	3	40	24	9,90
331 15 012	3,0	5	3	40	20	10,10
331 15 013	3,5	5	3	50	45	13,40
331 15 014	4,0	5	3	50	45	13,60
331 15 015	4,5	5	3	50	45	14,00
331 15 016	5,0	7	3	50	43	14,60
331 15 017	6,0	7	6	80	60	16,10
331 15 018	7,0	8	6	80	72	19,00
331 15 019	8,0	10	6	80	70	20,10
331 15 020	10,0	10	6	80	70	24,80
331 15 021	12,0	10	6	80	70	28,50
331 15 022	15,0	10	6	80	70	32,00

Mengenrabatte auf Anfrage / Quantity discount on request